



General Product Overview



ACO Systems and Solutions Private Limited

Head Office

Unit No: 116 - 118, First Floor,
No: 12, Richmond Towers,
Richmond Road,
Bangalore - 560 025
Phone: +91 80 2248 5487/ 2248 5488
Email: acoindia@acosystems.in
Web: www.aco.in

Regional Offices

Unit No: 4B - 43
4th Floor, Paragon Plaza,
Phoenix Market City, L.B.S. Marg
Kurla (W), Mumbai - 400 070

Unit No: 220 A,
2nd Floor,
DLF Towers, Jasola,
Delhi - 110 025

ACO Systems and Solutions Private Limited

Your Partner in Water Management Solutions



www.aco.in



[ACOGROUP](https://www.facebook.com/ACOGROUP)



[ACO India](https://www.linkedin.com/company/aco-india)

ACO. Creating the future of drainage

ACO Systems and Solutions Private Limited

Your Partner in Water Management Solutions





Content

About ACO

The ACO Group	2
The ACO India	3
ACO materials	5
The ACO system chain	7
Four guiding questions in surface water management	9

External Drainage

Line drainage system	13
Multiline drainage channel	15
Versatile gratings	17
Monoblock	19
Large capacity	21
Roadside drainage	23
Slotted channel systems	25
Freestyle	27
Drainage and lighting	29
Composite channels	31
Individual solutions in stainless steel	33
Point drains	35
Road gully	37
Domestic and economical solutions	39
Point drainage system	41

Building Drainage

Floor gullies	45
Shower channels	47
Stainless steel drainage	49
ACO modular and slot channels	52
Pipe work systems and balcony drains	53
Gravity roof drainage	55
Keeping the dirt out	56

Separators Technology

Grease separators	59
Light liquid separators	61
Backflow stops	62
Lifting systems	63

Special Business Fields

ACO Sport drainage systems	67
Construction elements and accessories	69
Access and Manhole covers	71

ACO References India	73
ACO References International	75
The ACO Group companies worldwide	76

ACO. Creating the future of drainage

ACO Worldwide

We are present with independent companies in over 40 countries in all continents. The backbone of ACO group is its global presence which consists of 30 production sites in places like Germany, United Kingdom, Czech Republic, Russia, USA and China. ACO group also operates sales & marketing offices in more than 40 countries. Respecting national cultural differences, the focus of our marketing activities is always the ACO brand with its excellent image, high quality standards and unique competence.

ACO Group is the worldwide leader in the manufacture and supply of drainage technology for external and internal applications. With more than 50 years of valuable experience ACO stands for professional drainage, efficient cleaning, and the controlled discharge or reuse of water.



5,000

Employees in more than 40 countries
(Europe, America, Asia, Australia, Africa)

30

Production sites in 15 countries



The Headquarters of the ACO Group
Rendsburg, Germany





ACO Academy
Rendsburg, Germany



Managing Partners
Hans-Julius Ahlmann and his son Iver Ahlmann



ACO India

-  ACO Office
-  ACO Sales Representative
-  ACO Channel Partner

ACO India

Incorporated in the year 2006, ACO India markets and sells a complete range of water management solutions for the Indian market. ACO India is equipped with excellent infrastructure, dedicated sales organisation and network of channel partners to provide a world class solution for all surface water drainage and water management applications.

Serving from our main office in Bengaluru and our sales offices in New Delhi and Mumbai, ACO India brings to its Indian customers a highly specialized range of German technology products with worldwide recognition only to evolve optimized, efficient and reliable water management solutions.

Our dedicated team of application engineers are available for training, supporting and advising our customers - Architects, Designers, Developers and Contractors in designing and executing the most efficient water management systems during the project construction phase.

ACO materials

In the design of components and structural elements, the choice of suitable material determines the aesthetic and functional qualities of the product. The materials used by ACO are characterised by their strength, ageing resistance and their resistance to aggressive media, frost, heat and sunlight. Thanks to their long life and recyclability, they are equally sustainable and environmentally compatible and are used in an application-orientated way.

With 30 production locations worldwide, we consistently implement our ideas of product quality, economic efficiency and on-time delivery to our customers. Each of our factories has special materials expertise, from which the entire ACO Group profits. As a part of our standards of acting responsibly as a company and to be a worldwide leader we constantly keep our production technology and ecological performance up-to-date and in line with the latest standards.

Our modern, state of the art manufacturing plant produces high quality products which have been used in worldwide projects.

- ISO 9001
- EN 1433
- EN 124
- KIWA – Third Party Control
- MPA – Material Testing Institute
- LGA – German Quality Institute
- LET – Quality Association for Drainage Technology
- DIBT – German Institute for Building Technology
- Member of the World Plumbing Council



Polymer concrete



ACO Polymer Concrete – A better idea

The special material composition and state-of-the-art production technology give polymer concrete its outstanding properties profile. ACO polymer concrete products have high strength values and a low weight. ACO polymer concrete is waterproof. Water dries quickly. Frost damage is excluded. The smooth surface of ACO polymer concrete allows water and dirt particles to run off quickly and is easy to clean. Polymer concrete is also resistant to aggressive media without requiring additional coatings and can be used variedly and durably even under extreme conditions.

Cast iron



ACO Cast Iron – Quality for all standards

Types of cast iron used by ACO in Kaiserslautern and Aarbergen are adapted to the continuously increasing requirements through intensive innovation and development processes: Both cast iron with lamellar graphite (grey cast iron GJL) and cast iron with nodular graphite (spheroidal cast iron GJS) have proven their worth as materials for use in cast iron sewers due to their high corrosion resistance. ACO offers the optimum solution for the respective application, independent of the material.

Steel/Stainless



ACO Steel/Stainless Steel – Sophisticated components

The processing of both steel and stainless steel is a core expertise of ACO in the different production facilities of the ACO Group worldwide. Large investment sums ensure that our production facilities are always state-of-the-art. The high qualification of our skilled workers ensure high-quality products. Our own in-house plants for surface protection and finishing are used, among other things, in the production of ACO Drainlock gratings.

Plastic



ACO Plastic – Innovative and flexible

Components made of plastic offer the greatest possible design freedom with regard to form and function. We use this potential to avoid expensive material combinations and time-consuming jointing processes and to develop intelligent solutions “cast in one piece” to take their place. The plastics used by ACO are characterised not only by their high breaking stress (crushing strength) but also by their outstanding resistance to environmental influences. Simple machining options and low weight are the reasons for the outstanding user-friendliness of our plastic solutions.

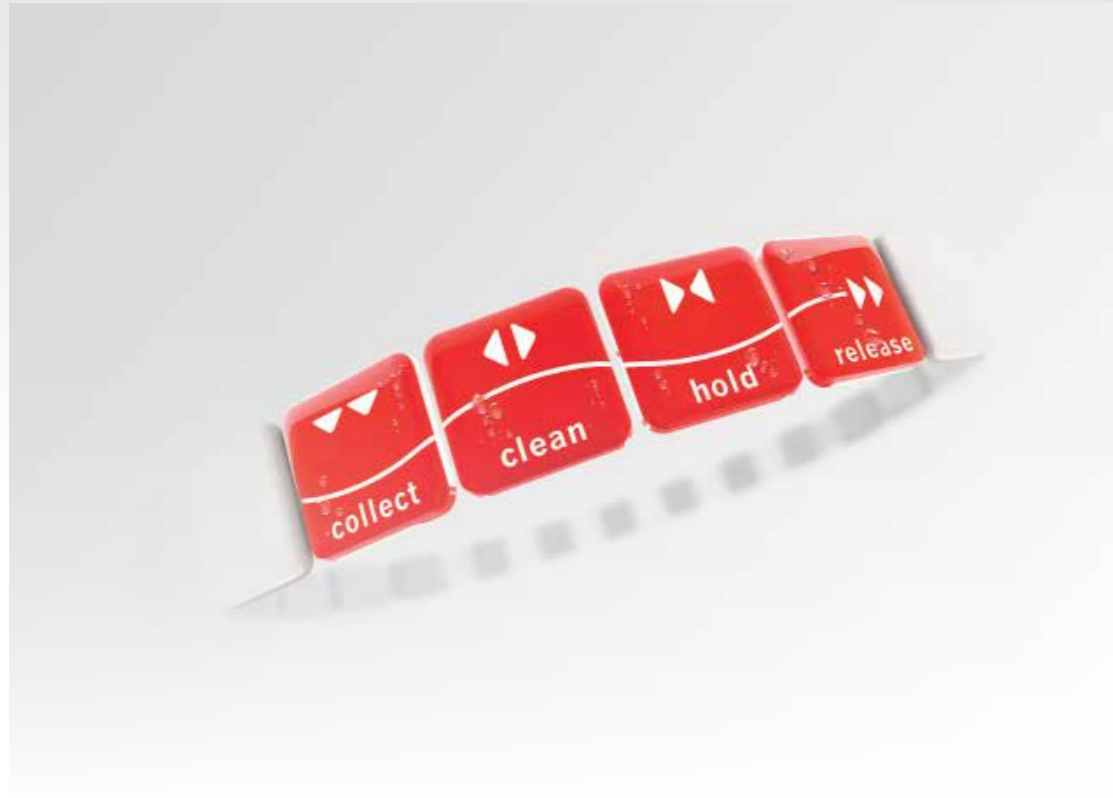

ACO. Creating
the future of drainage

The ACO system chain provides the drainage solutions for tomorrow's environmental conditions.

Increasingly extreme weather must be counteracted by more complex and sophisticated drainage concepts. ACO achieves this with intelligent system solutions which have a dual purpose: protecting people from water, and water from people.

Every ACO product within the ACO system chain therefore safely controls the water as it passes along the chain to ensure that it can be ecologically and economically reused in a viable way.

www.aco.in



ACO system chain in action



Four guiding questions in surface water management

How does the surface water management and water protection begin?

Collect

The surface water or the liquids being treated are collected from the surface as quickly and completely as possible by the drainage system. This part of the ACO system chain guarantees protection, safety and comfort for the people, buildings and traffic routes in the immediate vicinity.

How to achieve the right water quality?

Clean

The collected liquids are treated using integrated physical, chemical or biological processes that ensure they can be discharged into the public sewers – the minimum requirement. This part of the ACO system chain creates the conditions for recycling and sustainable use.

How to reduce surface runoff to a natural level?

Hold

Containers, barriers and valves ensure that the liquids stay within the drainage system where they can be properly controlled. This part of the ACO system chain enhances protection and safety for extreme situations: e.g. heavy rain, flooding or handling hazardous liquids.

How to control the discharge rate to the required level?

Release

Pumps, lifting plant and pipe systems transfer the collected, treated and controlled water into the downstream systems and processes. This part of the ACO system chain brings the collected, treated and controlled water to the interfaces for further treatment, re-use or release.

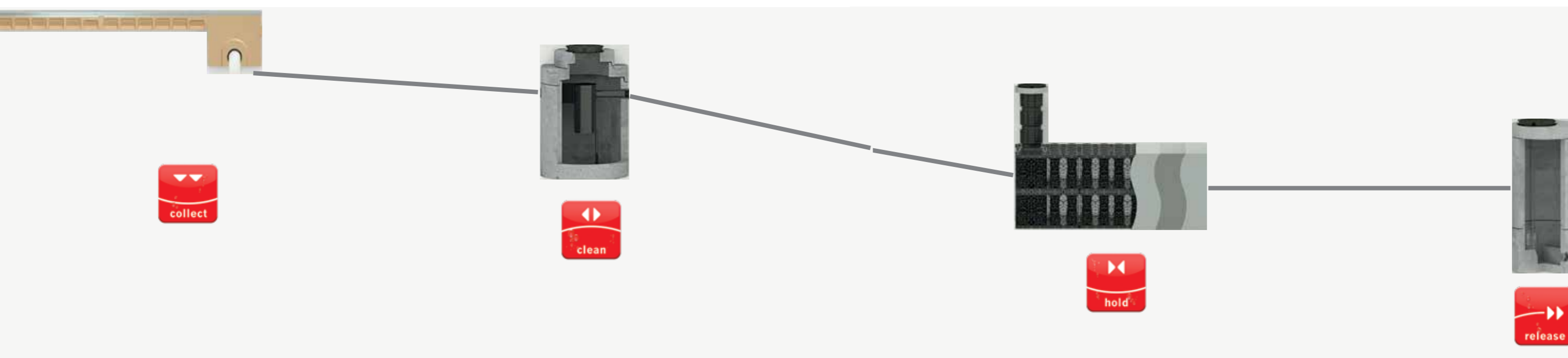

ACO surface water drainage

- Drainage channels
- Road gully and Combipoint
- Gully tops
- Manhole covers

ACO cleaning systems

- Separators
- Sedimentation and filtration systems

ACO infiltration/attenuation systems

- Control valve shafts
- Infiltration and attenuation systems

ACO control systems

- Flow control systems
- Pump shafts
- Lifting plants

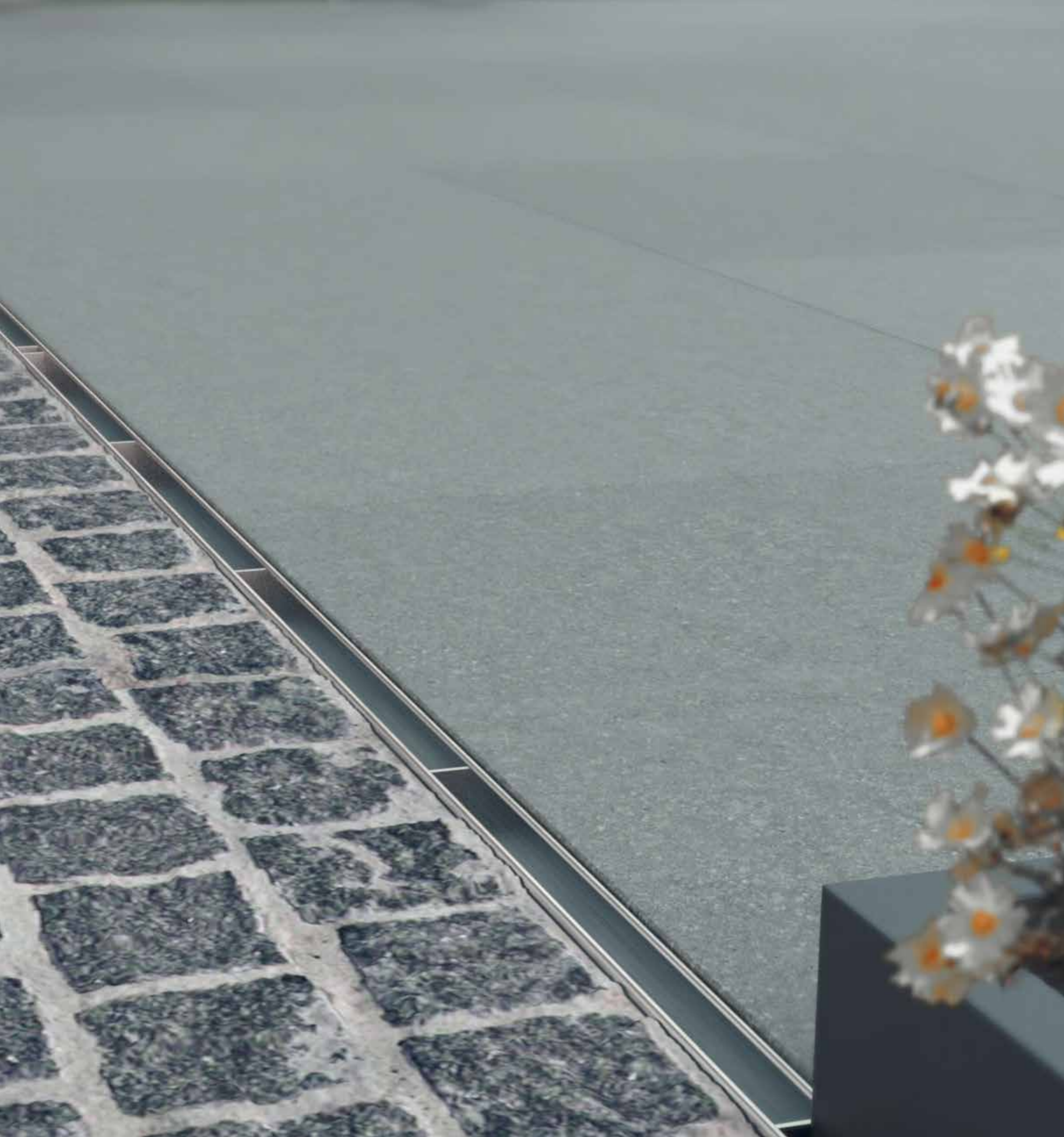

External Drainage

- ACO DRAIN® Line drainage system
- ACO DRAIN® Multiline drainage channel
- Versatile gratings for good-looking projects
- Monocast ACO DRAIN®
- Large capacity ACO Qmax
- ACO DRAIN® KerbDrain
- Slotted channel systems
- ACO Freestyle cast iron gratings
- ACO DRAIN® Lightline, ACO DRAIN® Sideline, ACO DRAIN® Lightpoint and ACO Eyeleds
- ACO XtraDrain
- ACO individual solutions in stainless steel
- ACO DRAIN® Point drains
- ACO road gully Combipoint PP

ACO DRAIN® Line drainage system

Freedom of design through Product Versatility

The drainage channel ACO DRAIN® Multiline collects the rainwater and leads it without loss to stormwater treatment and ultimately to natural rain water cycle. Thus it plays a crucial role to catch and discharge polluted surface water safe. Damage in buildings, weakening of concrete foundations and pollution of ground-water will thus be prevented.

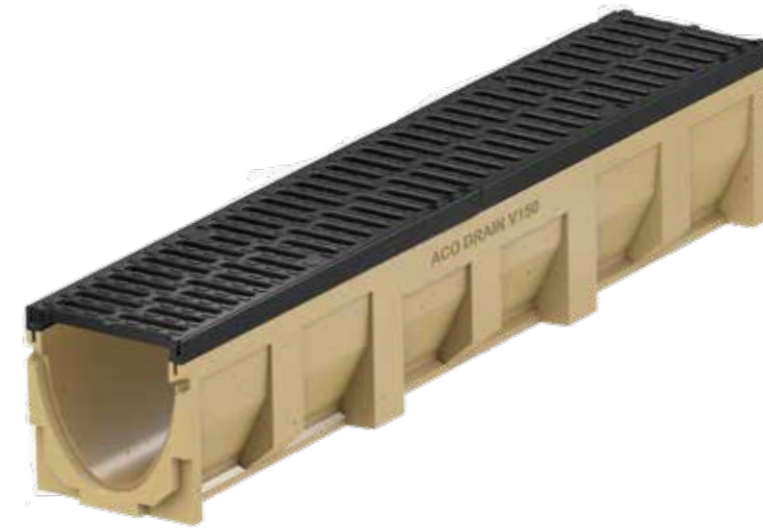

Features

- Made of ACO polymer concrete
- Tried-and trusted, simple installation
- Robust channel body
- Improved self-cleaning

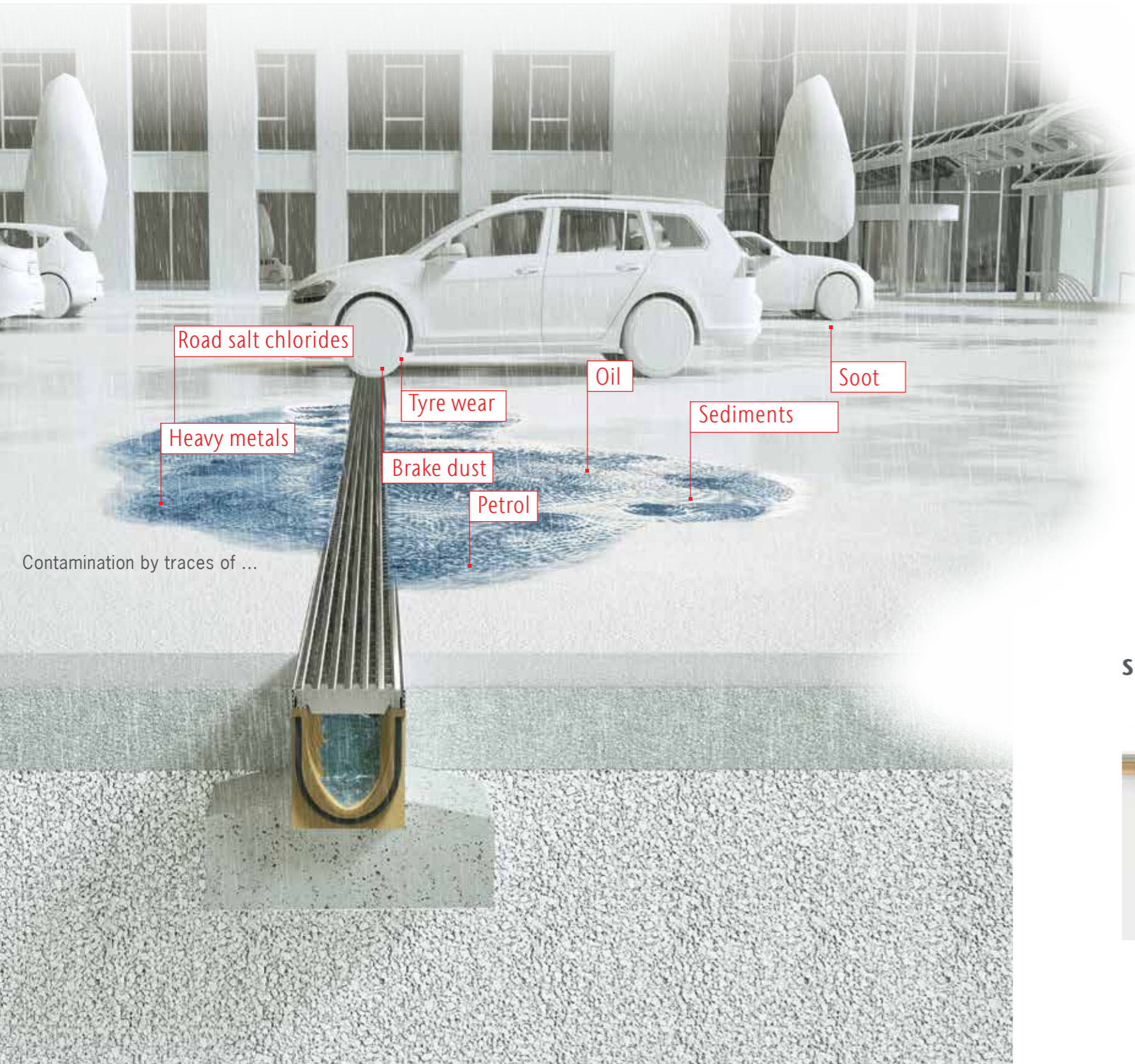

Structural Protection

Most structures are built on solid concrete foundations; these should be protected against the effect of chlorides in order to prevent corrosion and an associated weakening of the foundations.

Groundwater Protection

Recommended actions stipulate how to deal with rainwater on both public and private surfaces. The tightness of drainage has become more and more important in this regard.

Preventing irreversible damage early on

Rainwater that runs off from traffic areas often contains lots more impurities than one would expect: heavily frequented roads are exposed to harmful substances from tyres (wear), brake dust and

exhaust emissions, as well as traces of petrol and oil. That's not to mention deicing products used during the winter months. When it rains, all these impurities are inevitably washed into structures and groundwater, where they can cause considerable damage. For example, the chlorides present in road salt can lead to corrosion and a weakening of a building's foundations. The ACO DRAIN® Multiline drainage channel collects the water and feeds it to the rainwater treatment system, then finally into the natural rainwater cycle, without any avoidable loss. As such, it plays a crucial part in reliably collecting and diverting impure surface water. It is therefore possible to minimize irreversible damage caused to structures, the weakening of concrete foundations and the load to which groundwater is subjected from the very start.

Sustainable surface water management



ACO DRAIN®

Multiline drainage channel

The ACO drain programme is a genuine modular system; individual, personalised solutions can be combined from a range of channels, gratings and system accessories such as sump boxes - a system which will convince you in terms of technology and economy. take for example the ACO Drain Multiline line drainage system.

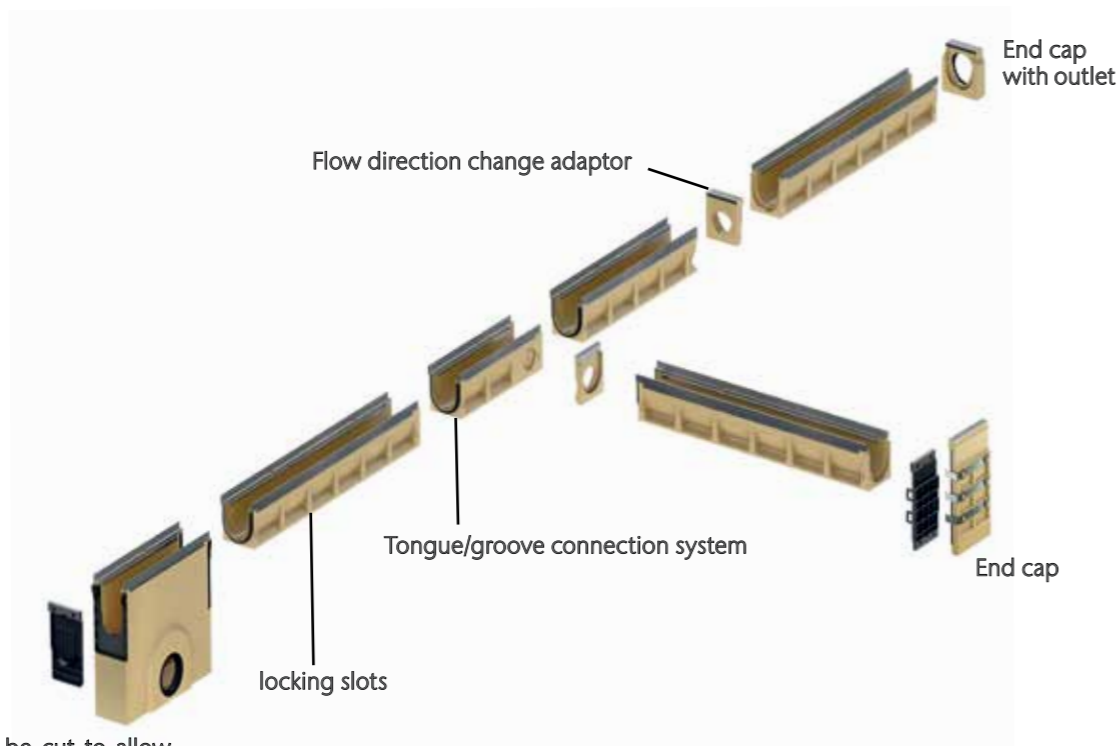

The sump box can be cut to allow any depth of channel connection

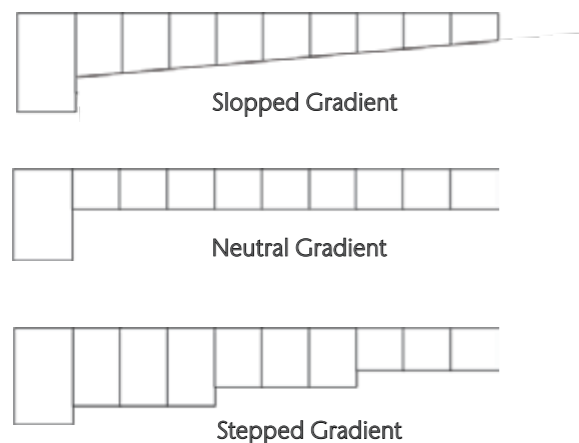

ACO Drain trench drainage systems are suitable for all types of gradients from sloped to neutral and also allow the combination of different gradient types.

ACO DRAIN® channel units have much higher strengths and lower weights for the same density as comparable concrete products. The low weight of the components simplifies handling and installation, and reduces costs. ACO polymer concrete is watertight. Water dries rapidly from the surface. Frost damage is totally excluded. The smooth surface of ACO polymer concrete allows water and dirt particles to run off quickly – making it easy to clean. Polymer concrete is also resistant to aggressive media without any need for extra coating and can be used flexibly and permanently even under extreme conditions. (See also ACO polymer concrete resistance catalogue.)

The superb properties of ACO polymer concrete reflect its special material composition and state-of-the-art ACO production technology:

- Bending tensile strength: > 22 N/mm²
- Compressive strength: > 90 N/mm²
- Module of elasticity: approx. 25 kN/mm²
- Density: 2.1 -2.3 g/cm³
- Water penetration depth: 0 mm
- Chemical resistance: high
- Surface roughness: approx. 25 µm

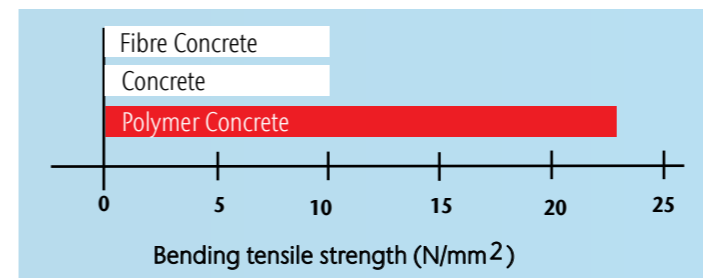

Bending tensile strengths of different materials used in drainage channels.

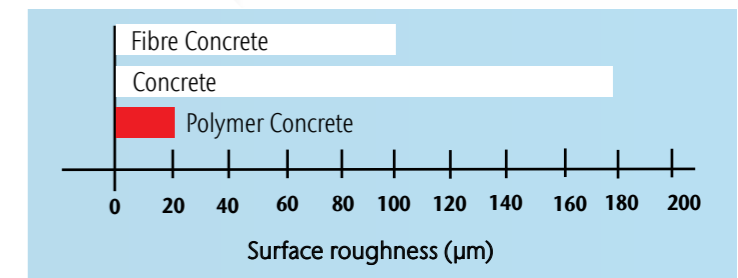

Average surface roughness of drainage channels made with different materials.

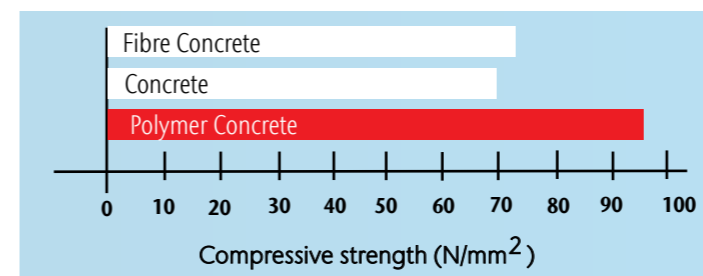

Compressive strength of different materials used in drainage channels.

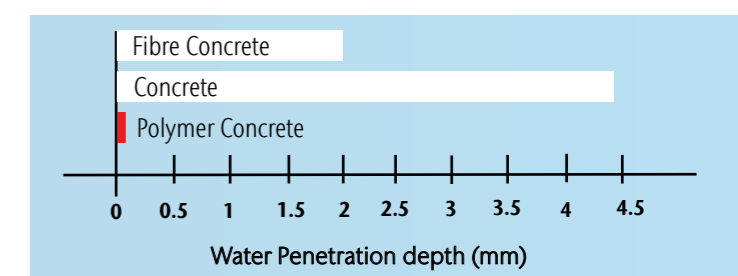

Water penetration depth (DIN 4281) after 72 hours of different materials used for making drainage channels:

The raw materials used to make ACO polymer concrete have to meet stringent specifications and pass continuous quality controls. In addition to our internal quality controls in accordance with DIN EN 1433, our products are also tested and third-party controlled by KIWA Germany. Homologation in accordance with DIN EN 1433 is conducted by MPA Eckernförde and MPA Lübeck.

Durable and recyclable:

ACO polymer concrete avoids waste because it can be returned to the production process. Normal concrete absorbs water because of the local climatic conditions, DIN EN 1433 together with the national tentative standard V 19580 require certification that normal concrete channels meet the highest quality standard "W". Polymer concrete is not required to fulfill these requirements because of its superb material properties!

Versatile gratings for good-looking projects

ACO Multiline drain can be combined with all Drainlock gratings, so there is a huge range of gratings available in lots of different shapes, colours and materials – be it cast iron or stainless steel, hot-dip galvanised steel or plastic. These options are able to meet any and all demands in terms of aesthetics, functionality and load.



Longitudinal profile grating

Galvanised steel
Stainless steel



Highlights from the A15 – E600 range of gratings

Longitudinal Web grating

Stainless steel



Mesh grating Q+

Galvanised steel
Stainless steel



Composite grating with microgrip

Anti-slip plastic



Awards for the longitudinal profile grating



Bar grating
Galvanised steel
Stainless steel
Ductile iron



Cross bar grating
Galvanised steel
Stainless steel



Perforated grating
Galvanised steel
Stainless steel



Bar grating Heelguard
Ductile iron



Bar grating
Ductile iron

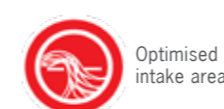

The system can hardly be compared with other channels - ACO DRAIN® PD 100 V and PD 200 V Monoblock is a one piece polymer concrete drainage system developed as a solution for a range of surface draining applications from load classes C 250 to F 900. It is a single component without any loose parts.

Monocast ACO DRAIN®

All purpose system



The channel is designed as an architectural element

The demands being made on drainage components are increasing constantly, especially with reference to design and aesthetics. The entire block is solidly coloured in anthracite black in the case of the PD 100 V Monoblock channel. The monoblock becomes an attractive element of design in this way.

The simple modular concept has various components in the system, which makes it suitable for solving the most diverse applications easily and neatly, thereby giving the greatest possible scope to the partner.

Installation and maintenance without any problems

The ACO DRAIN® PD 100 V and PD 200 V Monoblock are convincing because the system's parts are easy and economical to use. The monoblock can be installed like a kerb – with C12/15 grade concrete for the B 125 loading class – and it can be handled without slipping. No stiffeners are required. It can also be maintained without excessive cost. The monoblock is cleaned by rinsing it with a high-pressure or low-pressure jet of water; the half-metre long block has a removable grating that allows free access to the channel and the underlying inlet box.



ACO DRAIN® Monoblock D 200 V: Polymer concrete in a natural colour.

ACO DRAIN® Monoblock PD 100 V: Solidly coloured polymer concrete.

Polymer concrete makes Monoblock

- Light
- Age-resistant
- High-strength
- Rust-free
- Frost, de-icing salt and chemical resistant

Characteristic features of the product

- The innovative tongue-and-groove system enables the monoblocks to be universally laid together in any direction with the aid of a long crowbar
- Peripheral groove for the gasket
- 'V' cross-section
- Nominal widths 100, 150, 200 and 300
- Load classes C250 to F 900

Review of the RD 100 V/200 V system

Illustration shows the RD 200 V 0.0 (tight) version of ACO DRAIN® Monoblock

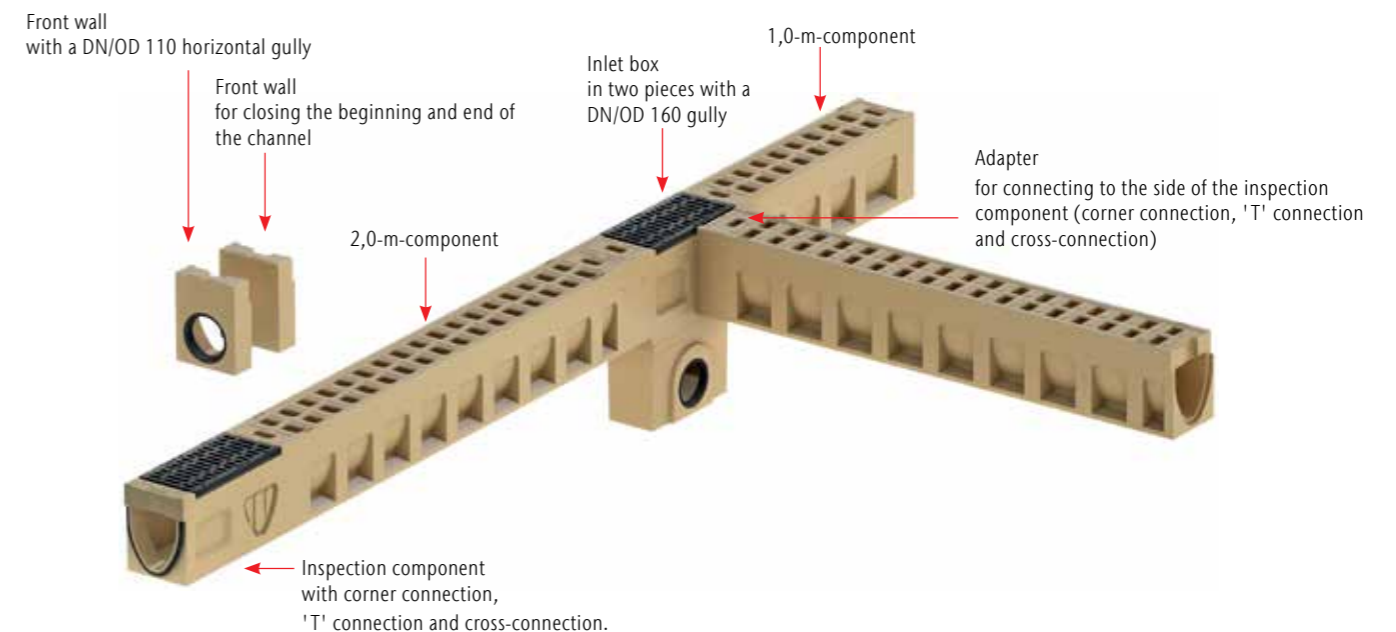

Typical Applications

- Line drainage on motorways
- Line drainage in inner-city areas
- Drainage across traffic lanes
- Industrial surfaces
- Airports
- Container transshipment areas
- Racing tracks

The ACO Qmax line drainage system has been developed to satisfy demands for economical high-capacity drainage systems for large catchment areas. ACO Qmax has passed independent load tests to class F 900 in accordance with EN 1433.

Large capacity ACO Qmax

An advanced drainage system



Qmax features

ACO Qmax is designed to handle high hydraulic capacities, enable minimum installation times and be lightweight and yet rigid enough to withstand the rigours of typical construction site handling practice. Manufactured from tough, chemically resistant medium density polyethylene (MDPE), ACO Qmax is light, easy to handle and quick to install. Connecting to pipes is also made easy with the availability of a special side inlet unit.

The ACO Qmax system is a patented design currently available in four sizes for effective and economical drainage of a range of catchment sizes: ACO Qmax 225 can carry flows of around 25 l/s even when laid level (depending on channel length etc.). The largest ACO Qmax 900 can carry flows of around 300 l/s when laid level and considerably more when laid with a gradient.



ACO Qmax is available in different sizes and lengths providing an effective and economical drainage solution for the application requirements.



Typical Applications

- Airport surfaces
- Distribution centres
- Highways
- Car parks



A new generation kerbs with integrated line drainage. KerbDrain stands for the brilliant concept of combining kerbstones with drains, to create one compact unit.

ACO DRAIN® KerbDrain

Roadside drainage



Two functions and one solution

ACO DRAIN® KerbDrain is made from one piece of polymer concrete kerbstone and it functions simultaneously as a drainage channel. The system's excellent hydraulic discharge rate throughout the kerbstone's length is convincing and therefore it offers an ideal solution for draining areas like roads, roundabouts and car parks. The Kerb Drain's standardized coloured concrete kerbstones make it suitable to use whenever a uniform aesthetic appearance is desired. Its advantageous cost results from low weight, a drainage channel that is integrated into the kerbstone and easy cleaning, starting from the installation to the final usage.

A versatile system

This intelligent modular system has channels for radii as well as inlet boxes with mud traps, chamfered kerbs and flat kerbs, which makes the ACO DRAIN® KerbDrain versatile to use. The openings of the inlets on the side have a cross-section of 147 cm²/m, which achieves a high and rapid draining performance. It is very effective not only in sensitive areas like bus stops – where great demands are made on effective drainage – but also in spacious areas where conventional construction requires a large number of gullies.

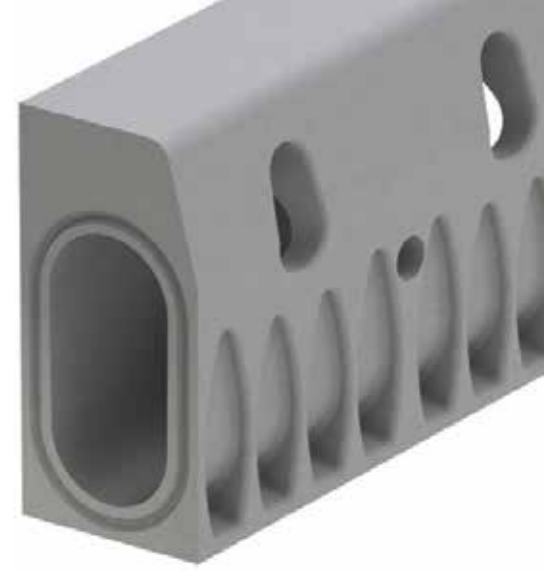

ACO DRAIN® KerbDrain
(available in heights 305 and 480 mm)



Kerbstone and drain in one, ACO DRAIN® KerbDrain

Roundabout application

ACO DRAIN® KerbDrain is ideal for draining roundabouts. It makes it possible to optimally drain the traffic lanes in roundabouts towards the inside or the outside, up to load class D 400. In addition, KerbDrain can be extended to optimally connect up to existing drainage systems.



ACO DRAIN® KerbDrain system is used at a bus stop:
Passengers enter the bus unobstructedly with the aid of the 18 cm high kerb.

Versatile

ACO DRAIN® KerbDrain is an extremely versatile system that can be used wherever drainage is required for paved surfaces, such as car parks, bus stops and traffic calming zones.

External Drainage

Discreet and inconspicuous, the V 100 S and V 150 S ACO DRAIN® slotted channel systems open up a new approach to designing open spaces. A narrow slot replaces the grating and forms a clean, line in the paving.

Slotted channel systems

Architecturally attractive solutions



ACO DRAIN® slotted channel system

Designing with clear lines

The system is also ideal for transitions between two different surfaces. The slotted frame consisting of galvanised steel or stainless steel is compatible with all standard paviers or stone slabs and joins the two surfaces almost seamlessly. This system is superb for the drainage of façades and optically sophisticated surfaces.

Functionality and maintenance

Simple cleaning and maintenance with low or high pressure washers. Access openings simplify maintenance of the subsurface polymer concrete or plastic channels with their excellent hydraulic performance.

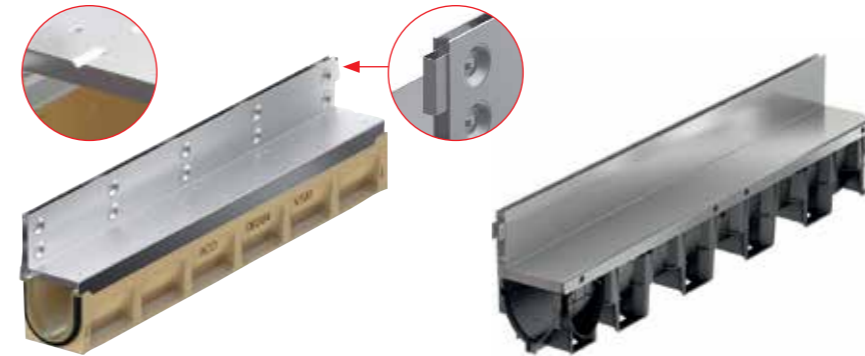

ACO Multiline Seal in with slotted frame made from polymer concrete

The plastic body of the ACO XtraDrain channel with a slotted frame



Typical Applications

- Piazzas
- Paths
- Facades

The slotted frame of the ACO Multiline drainage channel is technologically innovative and has an improved design. The draining angle (1) underneath the frame prevents the molecules of water adhering to the surface and therefore it improves the discharge of water directly into the channel. The new type of connector (2) optimizes aligning the slots when laying them on top of the channel.

The desire for individual solutions in landscape architecture can be met so easily when it comes to line drainage. With its Freestyle cast iron gratings, ACO provides unique design options for cast iron gratings.



ACO Freestyle cast iron gratings

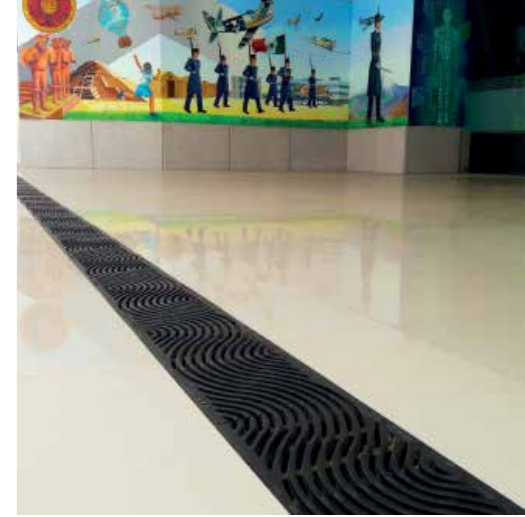

ACO cast iron gratings with LED lighting

A very special effect is achieved by the optional addition of ACO Eyeleds: the round LED lights, 20 mm in diameter, are supplied at the same time, securely fixed into the cast iron grating. This allows the individual design to be emphasised by lights that serve as a focal point.

ACO Freestyle cast iron gratings. Creativity in landscape architecture

An important and unique feature of ACO Freestyle cast iron gratings is the freedom given to the customer in designing the visible surface of the grating. Variable production tools enable imaginative and individual designs to be realised, which provide every planner with the opportunity to shape the appearance of the grating surface and, consequently, the open area to be drained. In this way, distinctive grating designs can be created and produced for special open areas in a very simple way.

- ACO Freestyle cast iron gratings are available with a nominal width of 100, 150, 200 and 300, each with a length of 500 mm
- Made of spheroidal graphite iron EN-GJS-500-7, coated or uncoated
- Load class D 400 as per EN 1433
- The screwless ACO Drainlock grating locking guarantees the gratings are securely locked into the drainage channel
- Customisable grating design

A new freedom in line drainage:

ACO Freestyle cast iron gratings can be easily shaped according to the design specifications of the customer.



ACO Freestyle "Flag"



ACO Freestyle "Leaf"



ACO Freestyle "Sturgeon"



ACO Freestyle "Animal Tracks" cast iron grating installed in Geilo, Norwegen

ACO DRAIN® Lightline, ACO DRAIN® Sideline, ACO DRAIN® Lightpoint and ACO Eyeleds provide highlights in architectural and open space designs. Public areas, entrance halls and paths become more attractive and more functionally designed. Technical perfection and individual design flexibility provide planners and builders with a wealth of versatile applications.

ACO DRAIN® Lightline, Sideline, Lightpoint and ACO Eyeleds

Architecturally attractive solutions

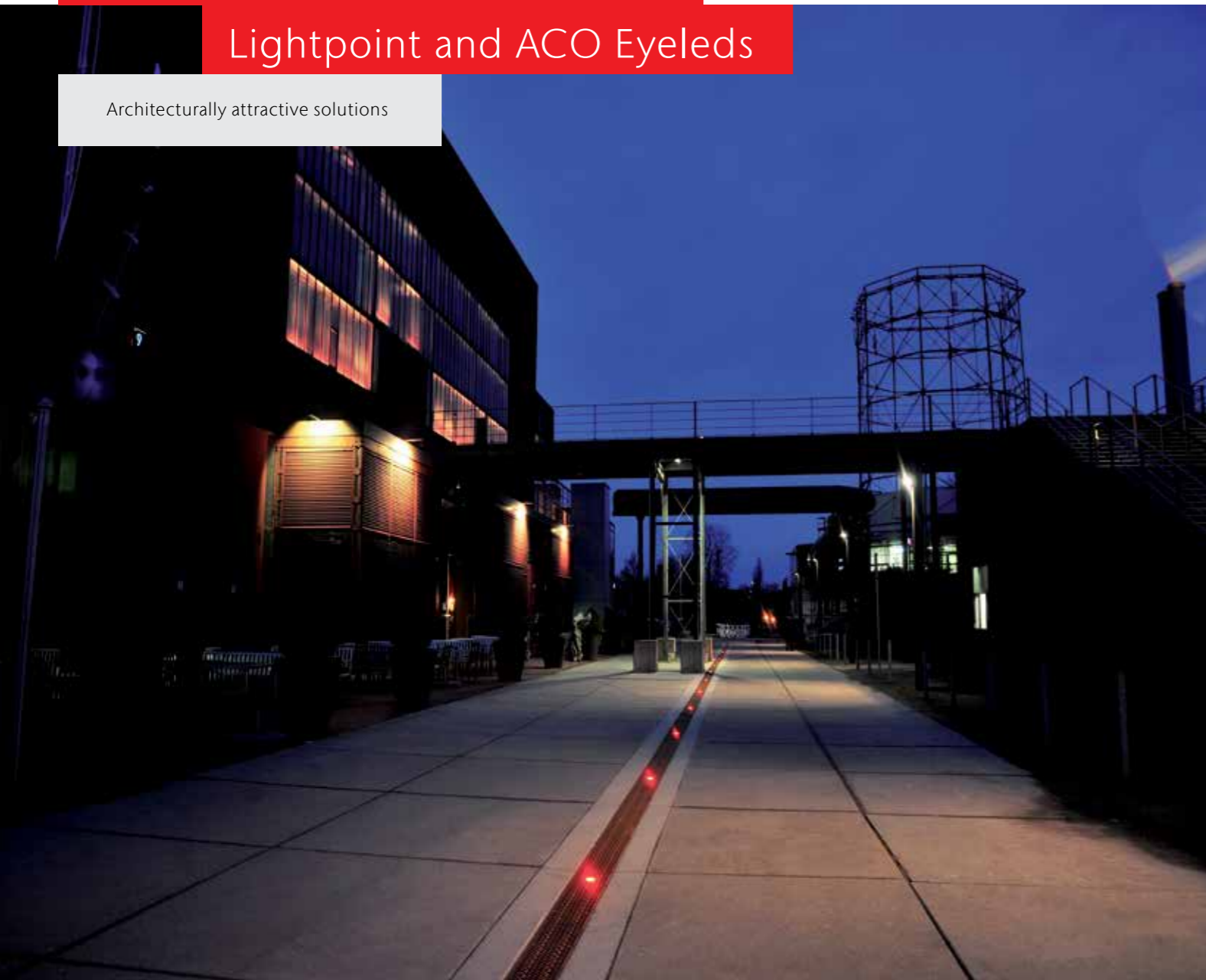

Typical Applications

- Piazzas
- Paths
- Entrance halls

Lighting instead of drainage – ACO DRAIN® Lightline

The new ACO DRAIN® Lightline with its variable colour effects provides planners with numerous application possibilities in the colour design of open spaces.

ACO DRAIN® Multiline channels in combination with LED Floorline and car-proof non-slip glass technology merge perfectly to create an architectural lighting design element. LED Floorline is

available in the standard colours white, blue and green. Other technologies are available for lighting with customised colours and for creating colour effects and sequences.

The ACO DRAIN® Lightline cover panel consists of a safety-glass cover which is non-slip and car-proof, and securely enclosed in a stainless steel frame.

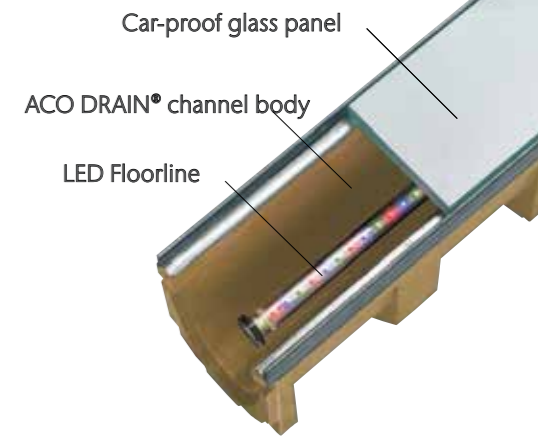

ACO DRAIN® Sideline

For some years now, drainage channels disguised as narrow slots have been upgrading squares and paths, as well as gardens and parks, with their clean lines. Slotted drainage channels have now become even more attractive with the addition of another design dimension: the new ACO Sideline stands out with its sophisticated symbiosis of drainage and LED technology. The enhanced feeling of safety is an important plus point in addition to the highly effective design character.



ACO DRAIN® Lightpoint

The LED Lightpoint is available in various colours (e.g. white, blue). 18 lightpoints can be run from a modular plug-in power supply unit. The lightpoints are interconnected by a simple plug arrangement.

The LED Lightpoint is simply inserted into the special opening in the ductile iron grate and fixed into place to retain the drainage function of the grate and the channel.



ACO Eyeleds

Light and expressive – the LED points are installed in a high-strength composite grating. The LED technology creates a powerful lighting effect even though the lights are only 2 cm in diameter. Garage drives, squares, footpaths, pedestrian zones, access routes, boulevards and railway platforms can all be attractively highlighted by ACO Eyeleds. In addition to decorative effects ACO Eyeleds can also improve overall safety in busy areas.



Trend-setting lighting and aesthetics in perfect harmony: ACO DRAIN® Lightline, Sideline, Lightpoint and Eyeleds for customised use.

External Drainage

The new ACO composite drainage channel XtraDrain: A great new drainage channel, especially for applications involving the design of open spaces, gardening and landscaping – which all benefit from this technically perfect and aesthetic solution for line drainage.

ACO XtraDrain

Composite channels for professional solutions

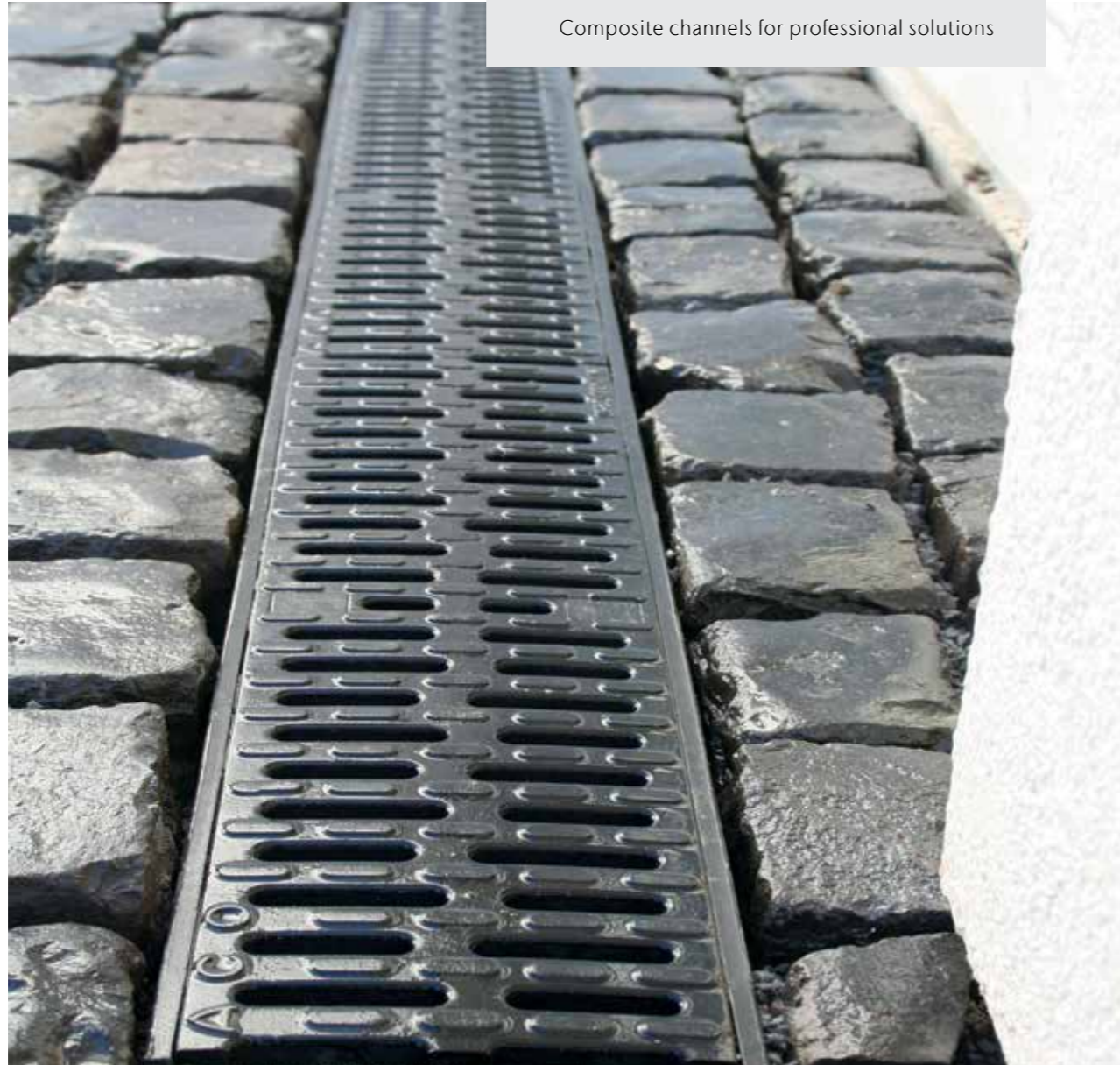

ACO composite channel

Manufactured from recycled polypropylene, the high quality, high strength unit is available in three channel widths; 100 mm, 150 mm and 200 mm. As standard channels are manufactured with galvanised steel or composite edge rails - which provide optimum channel protection from vehicular traffic.

It is possible to choose from a range of traditional and discreet slot drainage gratings and solid covers to ensure that a wide variety of applications are catered for. The

system's gratings are fitted with ACO Drainlock, a barless locking device which reduces the risk of blockages and improves hydraulic capacity.

ACO XtraDrain system also has a range of Brickslot gratings to complement installations which require a discreet drainage system. ACO Brickslot gratings are available in galvanised or stainless steel and are suitable for use with the 100 mm and 150 mm wide channels in the ACO XtraDrain range.

ACO XtraDrain

Easy handling right down to the last detail, combined with the highest quality. Technical details like for example the proven 'V' profile or the hexagonal shape of the side walls satisfy all of the demands that are made on a contemporary drainage channel. The high-speed flow and the good self-cleaning property minimize the cost of conserving and maintaining the channel system. The tongue-and-groove connection where the channel begins and ends enables this system to be installed simply and conveniently.

Typical Applications

- Footpaths, pedestrian areas
- Pedestrian precincts
- Public and private car parking spaces
- Open spaces around business premises such as banks, insurance companies, hospitals
- Housing areas/estates
- Schools
- Railway station entrances
- Façade drainage
- Railway platforms



The ACO XtraDrain provides a permanently attractive effect and functionality. Above: The photo shows the facade channel on the stadium of St. Pauli Football Club in Hamburg.



Cover gratings with the Drainlock screwless locking device are available for various models of the ACO XtraDrain drainage channel in the A 15 to C 250 loading classes.



The ACO XtraDrain drainage channel has a plastic composite grating. It is permanently resistant to corrosion and it is a visually attractive unit in the B 125 loading class.

External Drainage

In addition to perfect function, another key feature of ACO brand policy is the high aesthetic quality of its products. This gives rise to added value which is appreciated just as much by our customers as the professionals because many ACO products have already won awards for their innovative design.

ACO individual solutions in stainless steel

Accents for good architecture

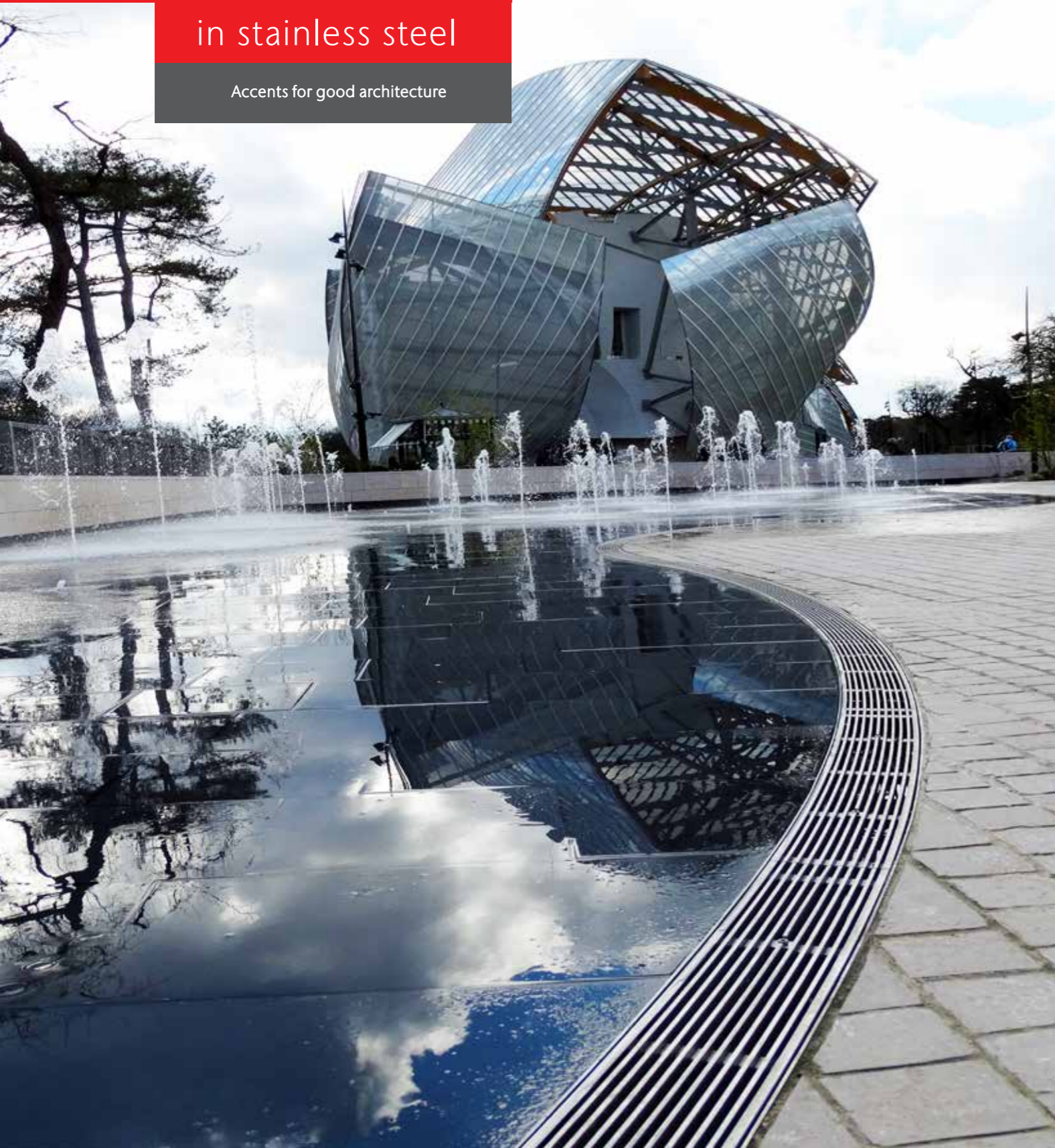

Customised for sophisticated planning

Form and Function

Chrome-nickel steel combines durability and beauty.

Form and function in perfect harmony. All of the components are durable, tough, non-deformable, corrosion-resistant and long-lived.

Design

The broad spectrum of finishes and shapes gives you complete freedom with your designs. Even unusual concepts can be easily realised using stainless steel. Customers individual project designs can be supported by our expert team with tailor-made services for your specific project with full proposal information, CAD layout drawings and assembly instructions.

Typical Applications

- Piazzas
- Facades
- Pedestrian areas
- Arcades and passages

ACO point drainage systems are ideal for surfaces which require point drainage for structural or topographical reasons.

ACO DRAIN® Point drains



Drainage precisely where it is needed

The yard drain is made from polymer concrete. The top has a ductile iron frame, an inset ductile iron grating and a Pointlock screwless locking system for loading classes up to B 125.

This system can be advantageously used in many areas:

- It can be installed with little handling.
- Versions of the system are available for all surfaces and loading classes up to B 125.
- It is supplied with a filtering bag for connecting to soakaway systems. The water will be cleaned in this way before it is conducted to the soakaway.



The yard gully is made from polymer concrete. It has a superimposed cast frame, an internally located cast frame or a grating made from galvanized steel mesh and it is fixed with the Pointlock system of screwless locking devices.



The levelling component for adjusting the installed height to match the paved surface, as well as the gully frames that can be stacked to raise the installed height, have a side connection, e.g., for downpipes.

ACO DRAIN® point gully

The ACO DRAIN® point Gully E 600 – F 900 is designed for all heavily loaded surfaces in industrial areas, airports and road gutters where it is required to utilize point drainage systems on the terrain because of technical reasons. This point gully has been developed especially for point drainage up to Class F 900 and it excels at high flexibility. The proven Powerlock screwless locking device ensures that it permanently opens and closes without any screws at all.



Typical Applications

- Roads, Paths, Piazzas
- Car parks
- Railway platforms
- School yards
- Industrial areas
- Airports

External Drainage

The innovative road gully ACO Combipoint has been specially developed to satisfy today's technological demands in the area of road drainage.

ACO road gully combipoint PP



A flexible modular system

The flexibility is new, but the material is as light and robust as ever. For the first time, the ACO Combipoint PP includes a plastic road gullies which can be twisted, telescoped, shortened and set at an angle. Thanks to their innovative modular construction, the gully bodies can be made a perfect fit to the local topography. The drainage modules, made out of highly resistant PP, only weigh 2.5 to 2.8 kg. The system is completed with gully tops in class C 250/ D 400. You can remove the need for mortar joints, which bring expensive renovation work. The load separation is taken care of by the telescopic principle within the drain components.

- Typical Applications
- Kerbs
 - Traffic lanes
 - Car parks and industrial surfaces
 - School yards
 - Pedestrian zones

ACO riser units Multitop

The new riser unit designs for class C 250 to D 400 Multitop storm water discharges feature long service lives, easy handling and simple maintenance. The frames and grates are made of ductile iron. The most important detail is the unbreakable maintenance-free double hinge which allows the grid to be folded out to around 115 degrees on either side or completely removed. 4-point vibration absorption integrated within the frame reduces rattling noises. Other features include the low weight of the grate and the grate securing system using a boltless non-corroding spring lock.



The ACO Combipoint PP system is the first system made of plastic that can be rotated, stretched or shortened telescopically

- Rotatable – for optimal pipe-connection
- Telescopic – for flexible height adjustment
- Load decoupled – to avoid settling
- No mortar joints, therefore without weakness
- Light units – easy handling during installation



The riser units Multitop are available with a channel or flat profile (300 x 500 and 500 x 500)

ACO Self® drainage systems keep entrances, pathways and terraces free of rain and waste water, thus protecting the building fabric.



ACO Self®

Domestic and economical solutions



Modular system – a channel for every application

ACO Euroline drainage was developed especially for private usage and combines optimum standard with high-quality design. The covers can be produced from a range of different materials from galvanised powder painted steel through high-grade steel and cast to plastic. This allows for a wide array of design possibilities. The channel bodies are either made from plastic, polymer concrete or steel. You can create individual solutions for every construction situation using the modular principle.

Slotted top for ACO Self – More stylish looks for your outdoor areas

The ACO Self slotted top replaces the 12 cm wide drainage channel grating with a less than 2 cm wide slot which fits elegantly into the overall look – at the end of your drive, on your patio, or alongside a garage.

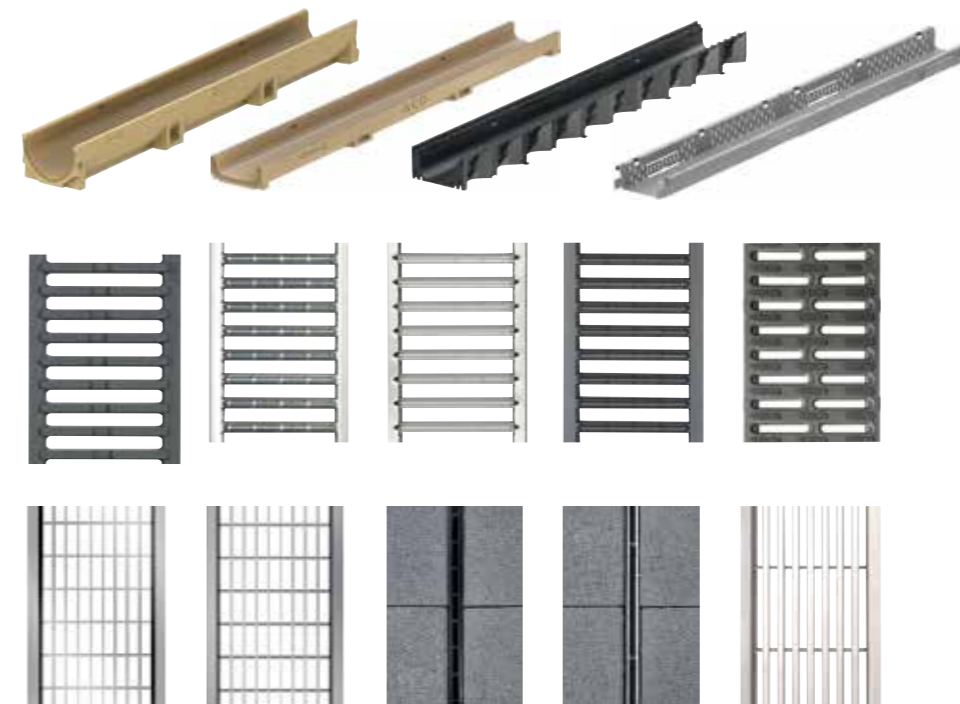

Typical Applications

- Garages
- Patios
- Drives
- Pedestrian areas

Point gullies are often used under the tap of a standpipe in the garden or yard, or as point drainage in suitable terrain. They work just like drainage channels while doing so. In other words, the gullies always drain the waste water and rainwater reliably, so that puddles and sludge do not have any chance to form.

ACO Self® Point drainage system



Typical Applications

- Car parks
- Domestic water tap
- School yards

Cobblestones, flagstones or asphalt are the customary coverings that are used nowadays for paving the areas around the house, as well as the large areas around public buildings and commercial buildings. Rainwater and waste water cannot soak away naturally because these pavings usually seal the ground. The pavings must not only be laid skilfully but they must also ensure that the surface water will be collected and drained in order to prevent puddles from forming. The ACO Self® Point gullies are a simple and practical solution for draining the surfaces of yards, driveways and large areas. The frostproof gullies for waste water and rainwater, which are passable by vehicles and resistant to thawing salt, reliably ensure that the surface water is collected quickly and drained via the point gullies from these areas or underneath the tap of a standpipe in the garden or yard.



The XtraPoint gullies made from plastic

- Passable by motor car (Class B125)
- Shallow installing height
- Large mud trap with a handle
- Permanently colourfast
- It is possible to pave directly up to the gully
- The gullies comply with DN 100
- The draining performance is at least 4.5 l/s



The yard gully made from polymer concrete

- Removable odour seal
- Removable mud trap
- Frostproof
- The depth of penetration by water into the polymer concrete is 0 mm
- The drainage capacity is up to 4.0 l/s
- Surface-draining performance: 150 m²

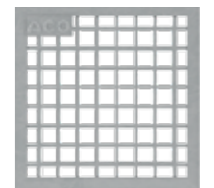

Mesh grating, galvanized steel

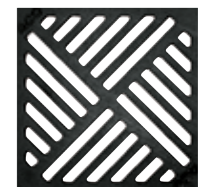

Ductile iron grating

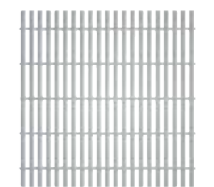

Longitudinal profile grating, stainless steel



Slotted grating, galvanized steel



Building Drainage

- ACO floor gullies
- ACO shower channels and point drains
- ACO stainless steel drainage - Hygiene First
- ACO pipe work systems and balcony drains of stainless steel and galvanised steel
- ACO gravity roof drainage
- ACO vario
- ACO backflow stops

ACO's product line includes a broad range of height-adjustable floor gullies suitable for any type of floor. Drainage is vertical or horizontal. The ACO modular system has a large number of flexible combination options for every installation situation.

ACO Floor gullies

A wide range of multi-application and high performance products



Floor gullies

A floor gully and drainage channel guide wastewater from floors into the drainage pipe, safely for people and without damage to structures. It is the installation location, for example, a large catering kitchen, which primarily determines which variant of a gully or channel for the drainage has to be selected. Depending on their type, they can be combined with extensions. ACO offers gullies made of cast iron, stainless steel and plastic.

The most important factors in the design include:

- Wastewater quantity
- Traffic load and load capacity of the grating
- Slip resistance
- Waterproofing/seals
- Fire protection requirements
- Hygienic properties



Fire protection floor gullies

ACO Passavant fire protection floor drains R 30 to R 120 with odour seals and vertical outlet sockets.

The ACO passavant fire protection floor drain series is made of inflammable ductile iron. A replaceable and retrofittable fire protection kit is fitted into the floor drains. The fire protection kit varies according to the floor drain and consists of a fire

protection odour seal with intumescent material in the head. This ensures safe sealing of the floor drain during a fire to prevent fires spreading from above the ceiling to below the ceiling. There is also a fire protection cartridge containing intumescent material which securely blocks off the floor drain and prevents fire spreading from beneath the ceiling

to the floor above.

"Preventative fire protection for all floor gullies" has attracted an increasing amount of interest in recent years – particularly for installation in buildings for special uses, e.g. hotels, hospitals, care homes or schools – where fire-resistance specifications already exist for ceilings and floors.



Function of the ACO Haustechnik fire protection floor drains before a fire



If a fire is present beneath the ceiling, the intumescent mass in the cartridge safely blocks the socket in the drain



A fire on top of the ceiling expands. The intumescent mass in the odour seal to completely block the drain

Function and design are combined perfectly in the ACO Showerdrain and the ACO designer gratings. The high-quality stainless steel look of the channel and the gully satisfy sophisticated demands for continuous level floors.

ACO Shower channels and point drains

Architecturally attractive solutions



Shower channels as design elements

The Showerdrain is a channel built into the shower floor which beautifully combines form with function.

The Showerdrain is the perfect high quality solution for high-class bathrooms featuring glass fixtures and natural stone floors, as well as public applications where the absence of barriers is an important consideration. The rigid channel body manufactured from stainless steel has a lateral channel gradient to ensure positive drainage of the water.

ACO designer gratings

The ACO stainless steel designer gratings are laser-cut and have an electro-polish finish. They are elegant, individual and superbly functional. The gratings fit the 150 x 150 mm and Ø 136 mm frames and are therefore used as standard with the MEKU or AV-SELECTA PP risers from ACO for the thin mortar bed sealing method. The risers can be combined with all ACO ductile iron and stainless steel gullies in sizes DN 50 and DN 70 on the plastic floor gullies DN 50-100.

ACO designer gratings can also be individually made to customer specifications. In addition to the patterns shown here, any other pattern can be cut out and customised from stainless steel plate.

ACO Showerdrains are available in standard lengths from 700 to 1000 mm. The Showerdrain is an attractive alternative to a conventional shower tray in high-class bathrooms as well as in public areas.

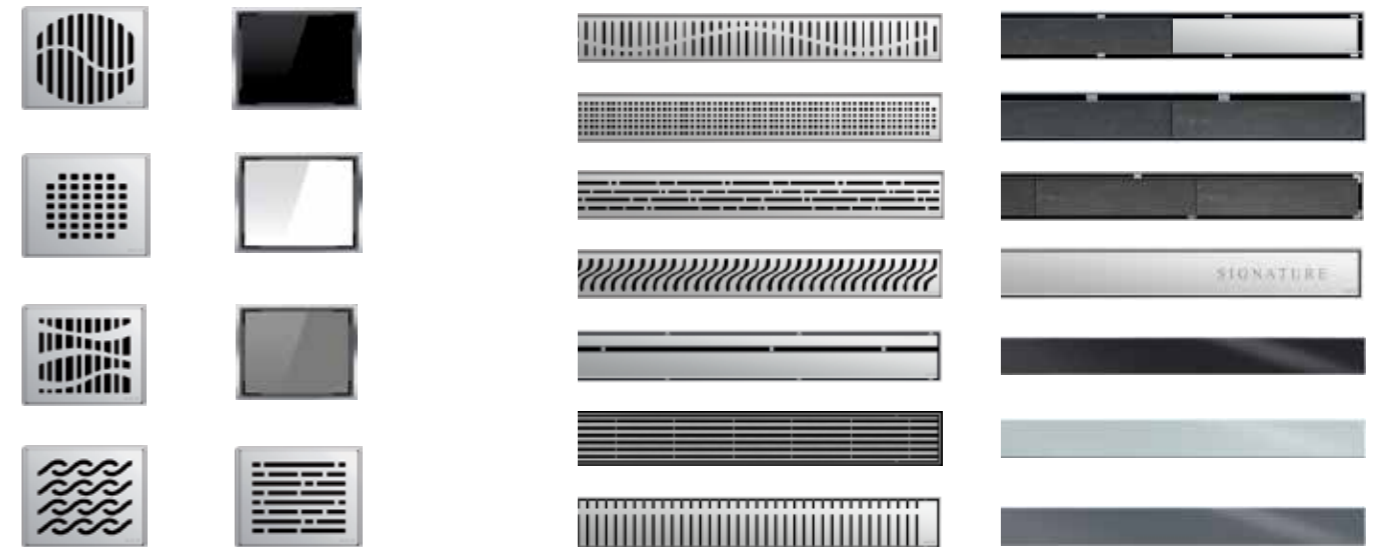

ACO Lightline Pro

ACO Lightline Pro allows you to create exclusive lighting designs in the bathroom. The floor lighting system produces impressive light effects, is easy to install, offers huge scope for design, and is extremely safe and durable. The idea behind ACO Lightline Pro is as simple as it is clever: A stainless steel U-profile filled with transparent resin to make it utterly leak tight

houses a strip of LED lights (protection class IP68) that is connected to the electric circuit and is therefore switchable. In addition to enhancing individual lighting design in modern private bathrooms, ACO Lightline Pro is also ideal for designing and implementing floor guidance systems in large spa and wellness facilities.



Stainless steel is the ideal material for applications where cleanliness and hygiene are the highest priority.

ACO stainless steel drainage



ACO stainless steel, because of its high strength, good metal-forming properties, corrosion resistance, and its smooth permanently attractive surface, stainless steel is highly prized as an extremely high quality, durable and hygienic material. It is virtually completely resistant to dirt, preservatives, micro-organisms and the proteins found in meat, blood, fat and drinks, etc. Proteins and bacteria do not readily adhere to the smooth surface and can be easily removed with suitable cleaning products and disinfectants.



Product benefits

- Channel widths from 150 mm to 500 mm
- Special edge profiles for abutment with tiles, artificial resin/mortar floors and thin mortar bed seals
- Range of gratings and covers for classes L 15 and M 125
- All stainless steel parts pickle passivated to ensure full corrosion protection

Customised solutions upon request

- Customised channel widths
- Material grade 316
- Extra-flat models
- Section types: NF, NFH and NK

Stainless steel drainage channels

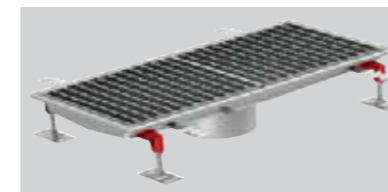

Drainage channels

A welded construction available upon request in various channel widths and channel lengths with customised pipe connections. Drainage channels with widths of 150 mm, 300 mm and 450 mm are produced as standard in 500 mm lengths ex warehouse.



Slotted drainage channel

Slotted channels are supplied ex-works in lengths of 1000 mm, 2500 mm and 5000 mm. Customised solutions can be easily manufactured upon request.

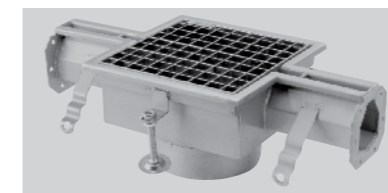

Modular

A wide range of high quality channels, gratings and industrial gullies, manufactured from 1.5 mm thick austenitic stainless steel provides practical solutions for floor drainage problems.

Stainless steel floor gullies

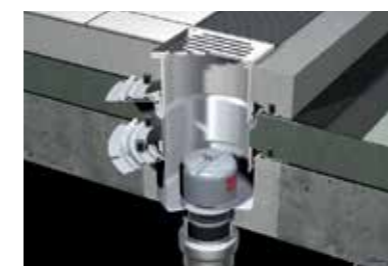

Floor gullies

Consists of floor gully units with nominal widths from DN 70 to DN 150, and risers with a range of gully gratings suitable for classes K 3 to M 125.

Available with fire protection sets for fire resistance classes R 30 – R 120

Product benefits

- Sophisticated modular system with floor gullies from DN 70 to DN 150
- Special AV-VARIANT riser element for thin mortar bed sealing
- Floor gullies with retaining edge, adhesive flange and pressed sealing flange
- All stainless steel parts pickle passivated in submersion baths
- Calibrated pipe connections for direct connection to SML pipe
- Non-slip gully gratings
- All gullies directly combinable with our drainage channels in stainless steel

Typical Applications

- Industrial kitchens in canteens, hospitals, care homes, businesses, catering companies
- Pubs, restaurants, fast food outlets, cafeterias
- Abattoirs and meat-processing industry, butchers
- Food and drink industry
- Pharmaceutical industry, cosmetics industry

Special models upon request e.g.:

- Risers with round gratings
- Gullies with lateral inflows
- Material grade 316

HygieneFirst

Food processing facilities are extremely sensitive environments with regards to food safety. As a result, our commitment to hygiene in this environment encompasses every aspect of the drainage process from initial design and installation, through to cleaning and maintenance.

Our products not only incorporate the hygienic design principles recommended by EHEDG, they are also the first to apply the EN 1672, EN ISO 14159 standards that are normally reserved for food contact equipment. Our products are also designed to connect hygienically with surrounding floors to minimise the risk of bacterial growth throughout the drainage system.

ACO Hygienic Gully:

ACO hygienic gully range incorporates hygienic design principles to ensure the optimum hygienic performance. ACO hygienic gullies are available in three body sizes to cater for different flow rates and construction requirements including shallow construction depths and applications where preventative fire measures are required. ACO hygienic gullies are certified according to EN 1253.



ACO Hygienic Box Channel:

The ACO hygienic box channel range incorporates hygienic principles to ensure the optimum hygienic performance. It is ideal for applications where high standards of hygiene is required as they are capable of handling large volumes of fluid. ACO hygienic box channel are certified according to EN 1253.

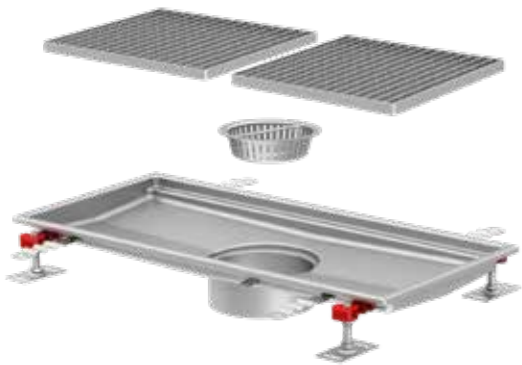

Internal Radii: All internal radii equal or larger than 3mm which greatly increases cleaning effectiveness

Hygienic Joints: Deep-drawn body ensures smooth contours eliminating crevices that can nest dangerous bacteria.

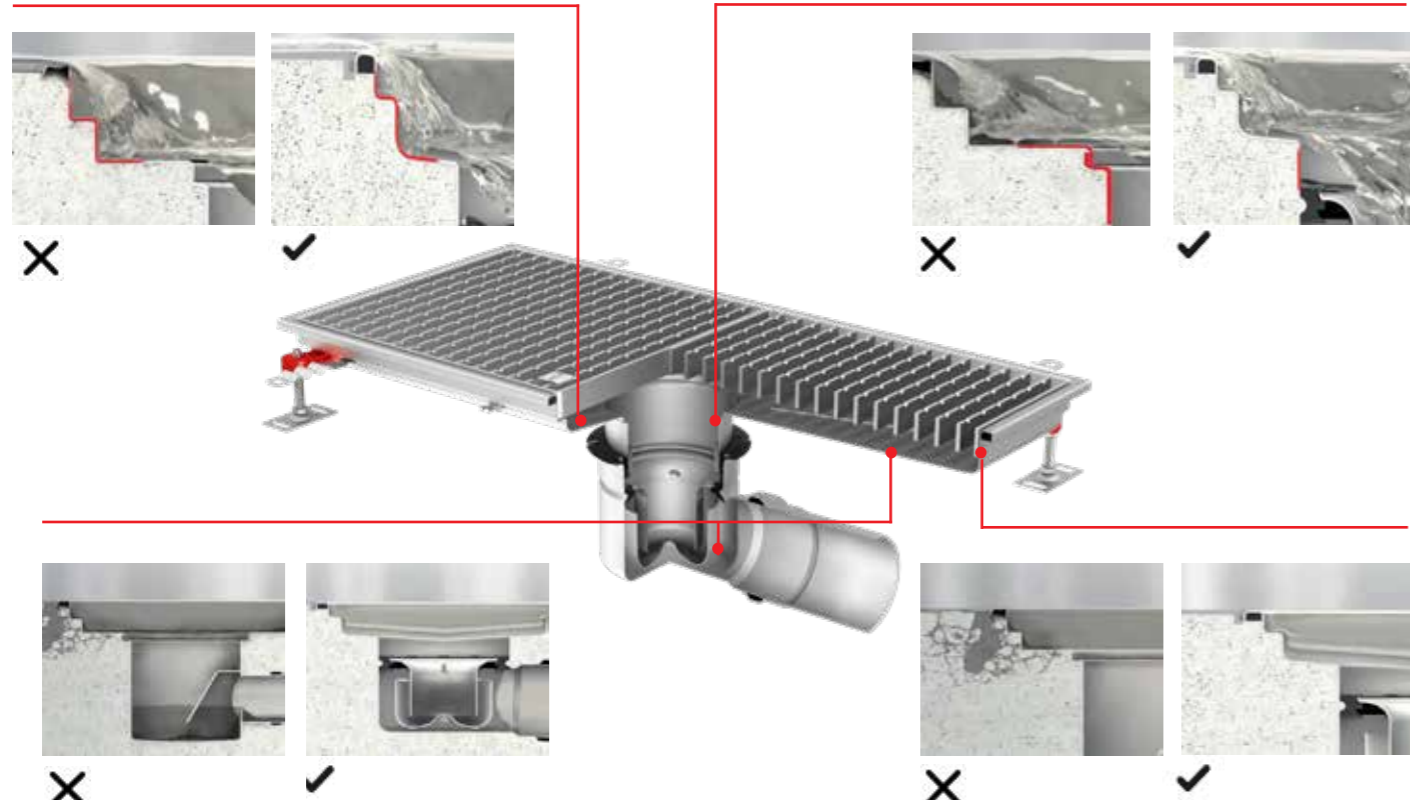

Dry Sump: Design, completely drainable - eliminating stagnant water, smells, microbial growth and potential chemical hazards.

Edge in-fill: Design ensuring stable and durable transmission between the drainage and surrounding floor and helps to minimize the risk of floor cracks that spur bacteria growth.

ACO Modular and Slot Channel

The ACO modular channel range includes for all common applications and all common floor types (concrete, tiles, resin or vinyl). Selecting a channel from the range is easy. The unique versatility of the whole portfolio makes it easy to choose the right channel according to specific needs of the customer.

Channel's length, depth and outlet position are just a few of the parameters which can be varied and, regardless of the various specified, there is no impact on delivery lead times.

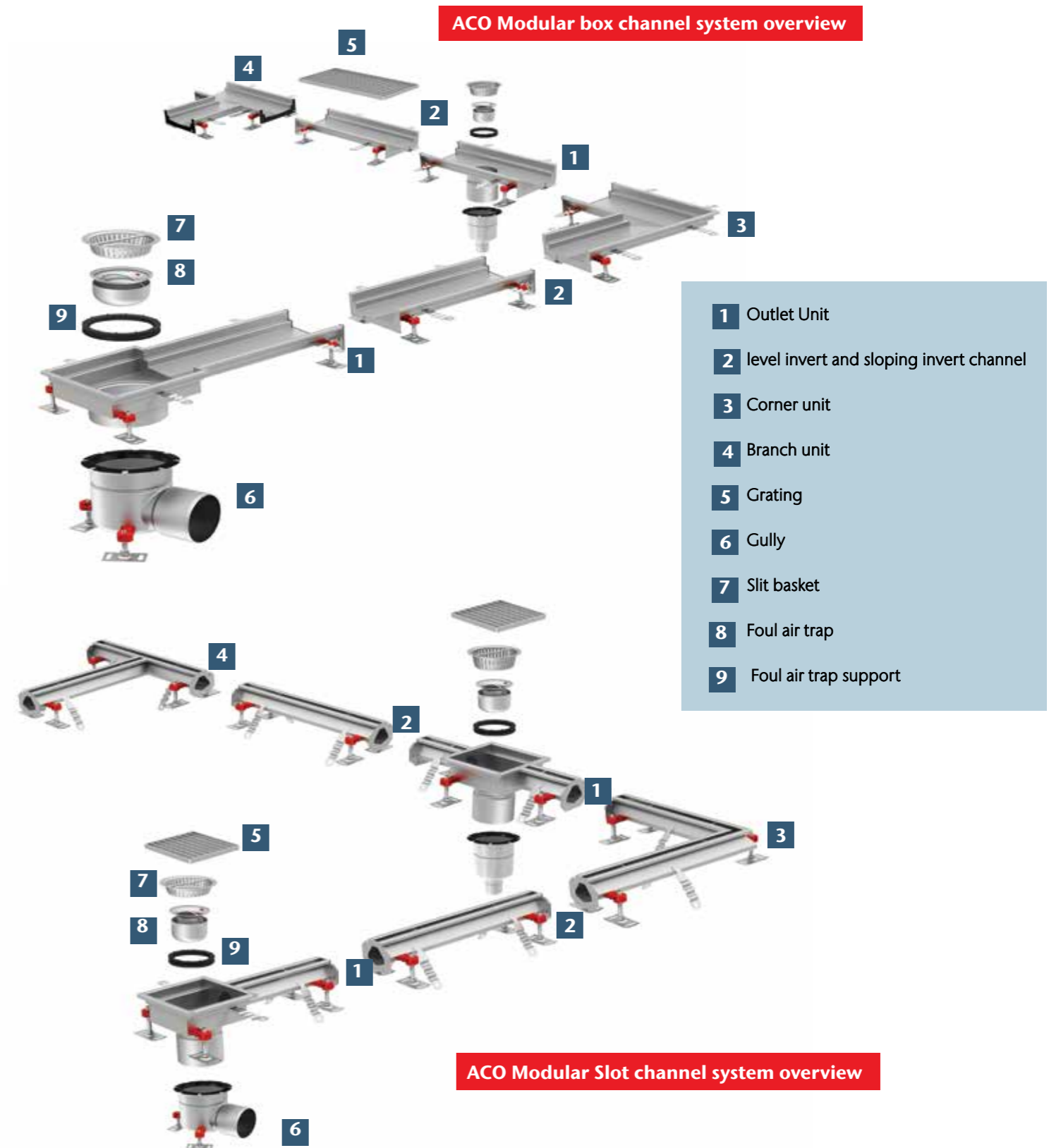

The functional strength and service lives of rainwater and sewage pipes are being increasingly challenged by the rising level of technology in homes, the growing demands for more housing and sanitation comfort, and the presence of aggressive media in domestic wastewater. ACO rises to this challenge with a complete programme of pipes, fittings and gullies in stainless steel and galvanised steel.

ACO pipe work systems and balcony drains of stainless steel and galvanised steel



Stainless steel pipe system

ACO PIPE is reliable, lightweight and durable push-fit pipe work system, designed, produced and tested for soil, waste, rainwater and industrial wastewater drainage applications. Together with the other products of ACO Group it creates a perfect system and offers a sustainable drainage solution with unique advantages to the customers. Especially with the ACO gully and ACO stainless steel channel systems provide a unique system for building drainage. The push-fit system ensures quick and easy assembly for a reliable installation for gravity and vacuum drainage.

Benefits

ACO PIPE stainless steel pipes save on installation costs and long-term care and maintenance

- highly corrosion resistant
- light and easy to handle
- very reliable double-seal joining system
- simple push-fit assembly
- low expansion co-efficient
- fire resistance

Balcony and terrace gullies

Different solutions are required depending on the installation situation when planning modern balcony and terrace drainage systems. ACO's balcony and terrace product line is therefore intelligently designed around a modular system. Everything starts with the drain bodies: depending on the model, drains with vertical or horizontal outlet sockets can be supplied and depending on the model, the drain body can be combined with intermediate sections and a range of top section systems which allows the right drainage solution to be created for each application and floor structure.

Typical Applications

- ACO PIPE stainless steel pipe is the fast alternative to ductile iron or PVC pipe systems, and is available in standard pipe sizes with easy to assemble push-on fittings.



ACO gravity roof drainage



Flat roofs are sensitive architectural areas. That is why it is especially critical to plan their drainage systems professionally. When rain falls onto a flat roof, large volumes of water can collect rapidly. Unless there is an effective way of draining off precipitation, this can lead to excess loads being placed on the building's structure. ACO Haustechnik offers functional solutions which are specially designed for flat roof areas and which ensure the water is drained effectively. For smaller surfaces, gravity drainage systems are the solution.

Typical Applications

- Flat roofs
- Terraces
- Hospitals
- Shops
- Car park deck drainage
- Green roof drainage



Gravity roof drainage

Flat roof gullies for gravity drainage are always used for draining small flat roofs with a surface area of less than 150 m² per gully. But this kind of drainage can also be used for larger roofs too. Whether the roof covering is a membrane, concrete or gravel: ACO Spin flat roof gullies can be flexibly adapted to the different requirements. The individual components of the gullies such as gratings, top sections and gully bodies can be combined as needed using our building block system.

With the correct accessory components the ACO Spin flat roof gullies can also be used to drain green roofs. Given increasingly dense construction in towns, more and more ecological surfaces are being sealed over. With an intensive or extensive green flat roof it is a relatively simple matter to compensate for this.

First impressions count – especially in an entrance area, which performs the function of a business card. An effective shoe scraper system is therefore an integral part of a well-designed and well-maintained entrance.



ACO Vario

Keeping the dirt out



Indoor shoe scraper anthrazite or grey
 ■ 60 x 40 cm
 ■ 75 x 50 cm

ACO offers professional solutions that are extremely variable and functional and also look good. Shoe scrapers that aren't permanently sliding around an entrance area are less annoying. ACO Vario shoe scrapers take care of dust and fine dirt. Keeping your entrance clean, and protecting your expensive flooring. The shoe scraper mats are framed to stop them from slipping, and are installed flush with the floor surface, so level access to the entrance area is easy to achieve. ACO shoe scraper systems are available in standard dimensions that meet the requirements of a huge range of installation situations. The shoe scrapers are easy to install and suitable for people building their own homes too, since they consist of prefabricated elements.



Choices of grates and mats are available for indoor and outdoor use to allow individual designs.
 ■ 60 x 40 cm
 ■ 75 x 50 cm
 ■ 100 x 50 cm

Polymer concrete tray – Vario (Outdoor)

- 60 x 40 cm
- 75 x 50 cm
- 100 x 50 cm

Plastic tray – Vario Light (Outdoor)

- 60 x 40 cm

Angle frame

- 60 x 40 cm
- 75 x 50 cm
- 100 x 50 cm

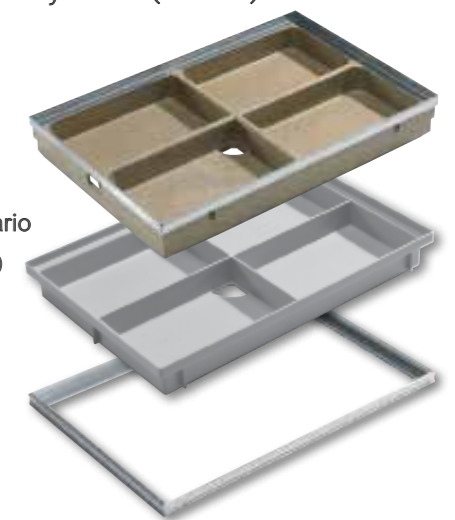

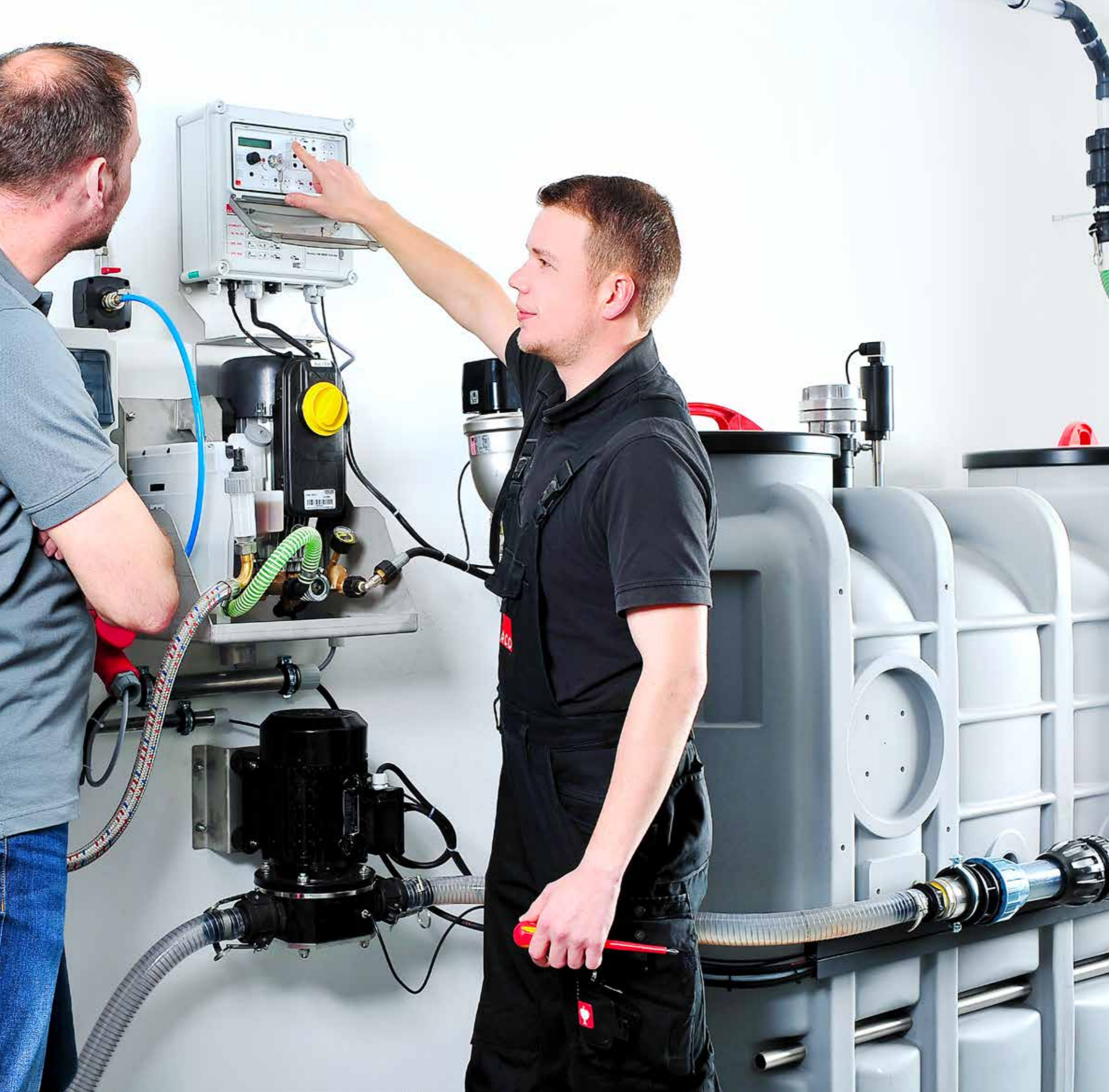

Separator Technology

- Grease separators
- Light liquid separators
- Lifting systems

Grease separators need to be adapt-able and versatile, and be available in various sizes and materials to meet the enormous range of different industrial and commercial needs. ACO has many years of experience in the production of grease separators. Its comprehensive product line includes free-standing and underground grease separators. Precise engineering and indepth expertise guarantee fully developed, quality-assured and completely tested products that satisfy all international standards.

ACO Passavant grease separators

Fully developed products compliant with international standards



Typical Applications

- Meat processing
- Kitchens
- Restaurants
- Grilling, roasting and frying kitchens
- Motorway services
- Catering facilities

The ACO product line has an optimum solution for every application. Free-standing grease separators are manufactured from stainless steel or polyethylene. In addition to the two materials, there are also two disposal systems: partial and full disposal. Partial disposal only involves disposal

of the grease and solids – this is carried out by ACO's manually operated LIPATOR or the fully-automatic LIPATOMAT. Partial disposal saves water and disposal costs. Full disposal grease separators remove all of the contents.

Grease separator for below ground installation are made of reinforced concrete or polyethylene. The Lipumax P grease separator series offers economic solutions and product variations as well enabling both easy disposal and tank cleaning.

Full disposal

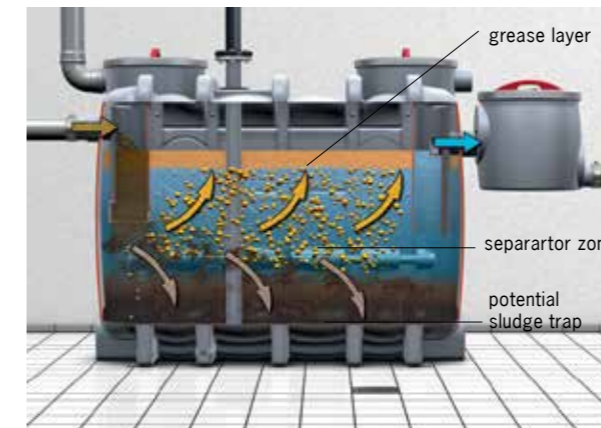

EN 1825 function diagram Grease separator with both integrated sludge trap and grease storage area

Partial disposal



The main applications of this type of grease separator are restaurants, canteens and catering operation kitchens. The grease collects in the upper cone. The sludge sinks to the bottom of the lower cone. The grease is kept fluid by heating the upper cone



LipuSmart

Product information:

- Program-controlled, odour-free disposal and cleaning by means of direct suction and hydromechanical internal cleaning
- Disposal connection DN 65, mating flange with Storz coupling 75B and blind connector 2½"
- Fill unit with solenoid valve
- Bluetooth interface (LipuSmart App/Android)
- Disposal pump with free flow impeller for total delivery head above 6 metres

ACO has completely upgraded its light-oil separators in response to the new European standard EN 858. This product line now sets new benchmarks for separator technology.

Light liquid separators

Pre-cleaning water endangering substances



Oleopator P

- With integrated silt trap
- With automatic shutoff when max. light liquid storage capacity is reached
- With coalescence insert



Light liquid separator system class 1 according to EN 858

According to EN 858, the plants are hydraulically tested and certified by LGA (Landesgewerbeanstalt) Bayern. Furthermore, the plants are inspected by LGA Bayern regularly, during which the assembly is checked for compliance with current standards. An existing static type test guarantees the stability for min. 50 years.

The following load classes are available:

- Load class A:** the walkable option – ideal for inner courts and grassed areas
- Load class B:** drivable by cars – perfect for drives and parking areas
- Load class D:** drivable by trucks – the safe solution for heavy vehicle loads and storage areas, as well as shoulders of roads

In an individual case, it can be useful to use a light liquid separator to EN 858 in conjunction with surface water infiltration or retention. Surface water can become contaminated, e.g. when it occurs on hardened surfaces. Surface water that has become mixed with light liquids of mineral origin in specific applications, must be treated via suitable separator systems or retention devices must be provided. The treated surface water must then be fed into the wastewater sewer (DIN 1999-100).

Laws, for example the law on prevention and remediation of environmental damage, require maximum operating safety of plants that handle water polluting liquids. ACO offers practical solutions with new and innovative technology.

If the contaminated surface water is to be discharged into a body of water, the respective authority must decide what treatment plant must be used depending on the degree of contamination and the sensitivity of the receiving water.

Typical Applications

- Petrol stations, car parks
- Car washes, vehicle washes
- Automotive workshops, automotive trade
- Filling areas, unloading zones
- Petroleum storages, maintenance operations
- Transformer stations, power plants
- Industry and commerce

ACO backflow

Compact design for versatile utilisation



Previously an occasional hazard, the risk of backflows will undoubtedly increase in future in line with the predicted greater frequency of heavy rain storms. This is because sewers are only designed to cope with average rainfall volumes for economic and technical reasons. Mixed water sewers can therefore very quickly fill up completely during major cloud bursts. It therefore only makes sense to permanently protect all rooms and areas in single family houses lying below the backflow level from the risk of backflow from public sewers.

Product benefits

- In-situ test according to EN 13564 already for DN 50/DN 70 possible
- Maintenance without tools
- Quick fasteners for cover locking
- DN 100 – DN 150 with large openings for inspection and cleaning
- With test funnel also for DN 50 and DN 70

ACO backflow stops for grey water

Various drainage situations require the appropriate product if protection against backflow is needed.

The ACO backflow stop series Triplex fulfills all demands defined in EN 13564 and fits for protection of drainage pipes conveying water or grey water from showers, sinks or washing machines below the backflow level.

The compact product dimensions enable quick and uncomplicated installation – for both new buildings and renovation.

The quick fasteners of the covers allow simple maintenance without the utilization of tools.

The ACO Triplex series is available in the dimensions DN 50 - 150.

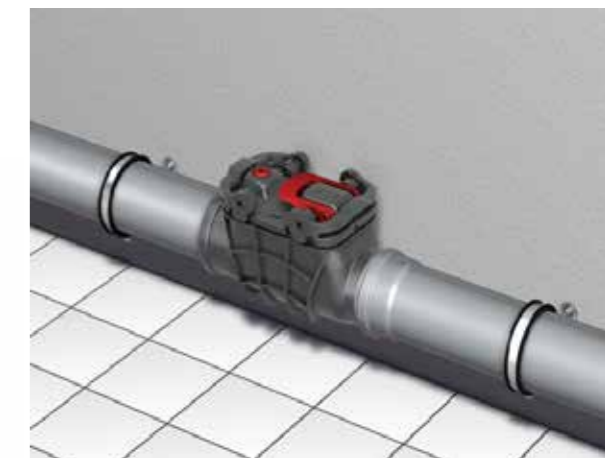

Easing of maintenance through innovative cover locking

Professional lift systems are one of the main areas of ACO product excellence in its building drainage product line. ACO has a complete range of intelligent solutions suitable for several application areas, as well as a flexible tank system enabling customization for specific requirements.

ACO lifting systems

a complete range for professionals



ACO wastewater lift plants

Muli-Star lifting plants are designed to raise wastewater from deeper lying rooms such as conveniences, cloakrooms, showers or complete bathrooms. Also available with a redundant unit for higher operating reliability in housing blocks or small offices.

Product benefits

- Optimum tank volume utilisation-less hysteresis and pump wear
- Microprocessor-controlled switchbox for simple operation
- Low-noise pumps
- Special connection piece for rapid assembly to pressure pipe

The Muli-Pro lift plants are mainly used in public and commercial buildings e.g. office buildings, schools, hotels and factories. These lift plants can be equipped with several lifting heights and flow rates.

Product benefits

- High-quality tank in polyethylene
- Designed for wastewater containing grey and black water
- Free diameter up to 100 mm
- Variable by up to four inflow connection options
- Wide scope for positioning in the installation space



Muli-Max F/ Powerlift P- pumping stations for non-soil wastewater and soil

Muli-Max F and Powerlift-P pump stations are suitable for below ground installation outside buildings.

These fully-fledged pumping stations are mainly used for draining surfaces and deeper lying areas in private and commercial buildings.

The complete pumping stations ensure optimal pressure pump drainage of domestic wastewater.

Product benefits

- Float-resistant PE tanks
- Encrustation-resistant collecting tank
- Low maintenance and flexible over-fill pressure switch
- Flexible inlet invert with raising tubes and covers for load class A, B or D



Powerlift- P



Muli-Max F

Pumping stations

Pumping stations are installed in already existing tank systems which are designated to serve a collecting for tanks for pump stations with submersible pumps. They are used for drainage of single or multiple family houses and larger courtyards and similar surfaces.

The pumps are available with several performance power for different lifting heights and flow rates.

Product benefits

- Selected combination of several materials for prolonged owntimes
- Pre-assembled pressure piping
- Construction height and interior customizable according to modular system
- Submersible coupling system with sliding tube





Special Business Field

- ACO SPORT drainage system
- Access Covers

ACO SPORT includes drainage systems and construction elements for sports and recreational facilities, helping them to remain in good playing condition throughout the year.

ACO SPORT drainage systems

for running tracks and sport facilities



The successful partnership between ACO and the Olympic Games first began in 1972. This was the year that ACO kitted out the award-winning "Olympiastadion" in Munich with ACO SPORT® products! Since then ACO has firmly established itself as a key partner to the largest sporting event in the world.



The hockey facility of the Olympic Games 2016 in Rio is equipped with ACO drainage channels



ACO SPORT® Drainage systems for athletics facilities Type A, B, C

Football grounds

Pitches in football stadiums are generally covered with real grass. However, many football pitches are covered with infilled artificial turf, to allow them to be used more intensively, for longer, without any deterioration in playability. The infill used in the artificial turf is a mixture of sand and rubber granules. This makes the surface very water-permeable, just like real grass. The ACO SPORT® shallow channel drainage

system has proven ideal for removing surface water from this kind of surface, and from adjacent auxiliary areas. Because of the low (15 mm) depth of these channels, which conforms to DIN 18035, they are safe, drain the water away reliably, and are easy to clean of granules. Because the sides of the symmetrical channel are only slightly off-vertical, it is easy to lay paving stones against it.



Sports pitches, games areas and recreation grounds

All-weather pitches, small sports surfaces, tennis and volleyball courts and leisure installations also all need to be quickly drained of surface water. The components used for drainage must also be extremely low-maintenance and sturdy, and must not pose a risk of injury.

ACO SPORT® shallow channels are the ideal solution, as demonstrated by many decades of use on numerous facilities of this kind. The channel is wide, compact, and securely anchored to the bedding material, meaning it is safe, sturdy, self-cleaning, and presents vandals with no point of attack. For point drainage of the sports surface, a robust stainless steel catch basin, covered with a grating with a small mesh to prevent injuries, is recommended. Concrete edging panels can additionally be used to form a wide border with adjacent areas of vegetation, providing long-term protection to sports surfaces with synthetic coverings. By surrounding these games surfaces with ACO SPORT® elastic perimeter kerbs, additional safety can be provided for users.

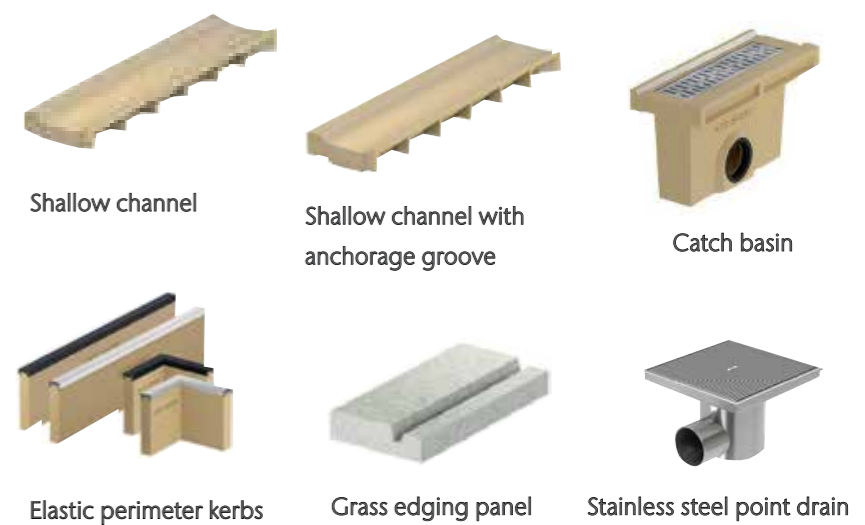

Shallow channel

Shallow channel with anchorage groove

Catch basin

Elastic perimeter kerbs

Grass edging panel

Stainless steel point drain

Example Type B arena

Type B sports facilities are not only used for athletics, but primarily for football or other ball games. To make sure the playing conditions are safe for all users, particularly due to the 5 cm high border required around the running track, the large playing area is also built 5 cm above the level of the running track. This means the border edge can be permanently installed on the raised edge of the playing field directly, by means of a hidden channel construction, thus

presenting no obstacle to step over. The sectors designed as artificial surfaces for athletics competitions run flush with the level of the running track at the prescribed surface gradient.

The ACO SPORT® NW 125 drainage system is a combination of hidden channels and hollow-profile channels. The system intelligently unites fast surface drainage of the sporting surfaces and the particular requirements of all

users of modern sports facilities. For example, if there is a raised playing field, the drainage is routed through hidden channels designed as box channels with a stationary stable cover, which also serves as the 5 cm high border around the running track. The channels are raised above the side of the playing field via a 4 cm high cast-on turf support. Water enters from the running track at the side, through the supported plastic cover with its inlet slots that conform to standard.

The sectors are drained via integrated hollow-profile channels, which are layered over with a synthetic surface in situ. The plastic cover and its mobile elements are plugged into the slots arranged above the running track in order to create the required border around it. This border can be dismantled quickly, which means the sectors can be accessed easily from the running track, thus ensuring technical discipline as regards athletics.

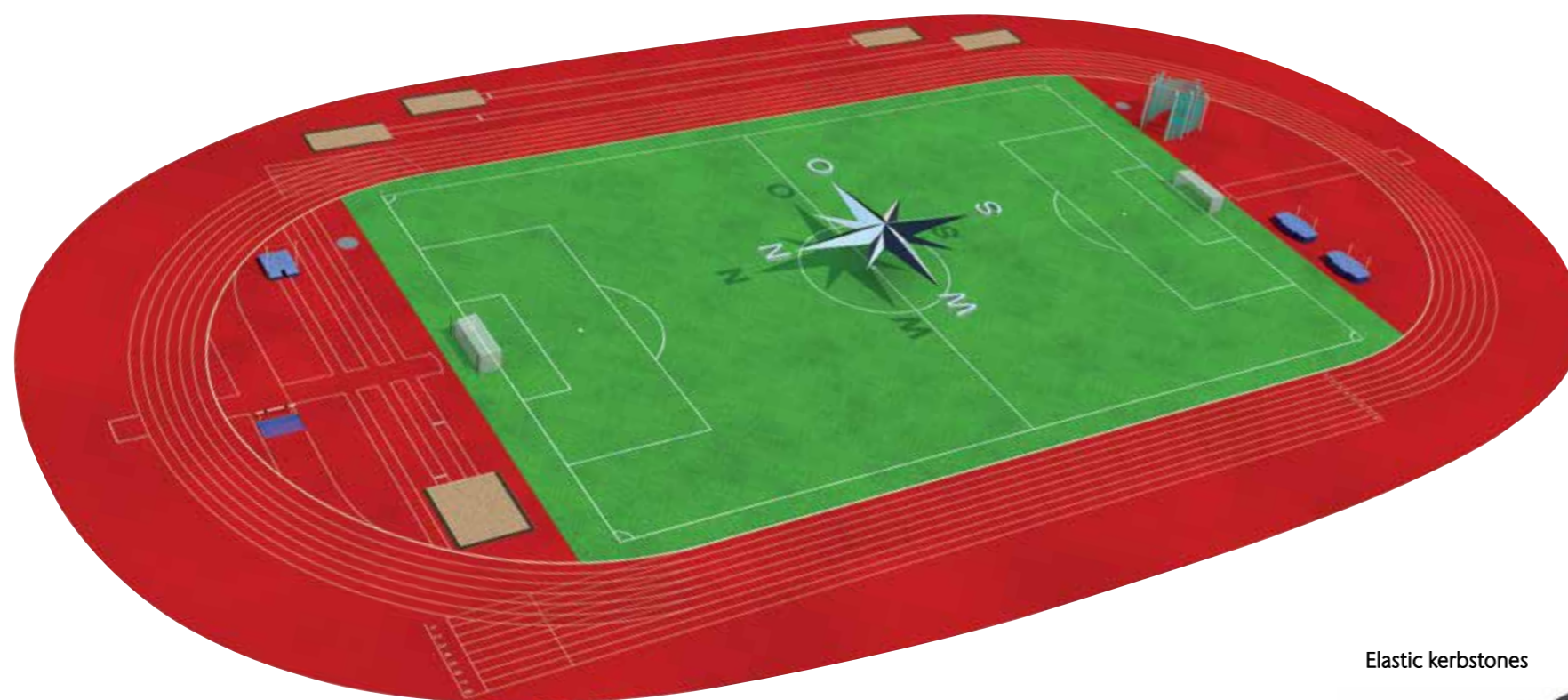

Sport surrounding kerb



Cable distribution shaft



Sand capture channel



Elastic kerbstones



Inlet shaft for slot channel and inspection box



Hidden box channel

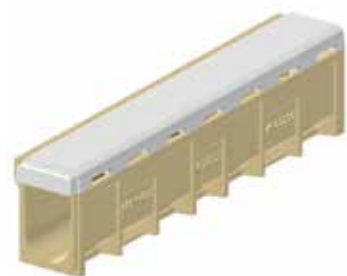

Slot channel clear width 125 plastic cover can be layered over, moved and detached

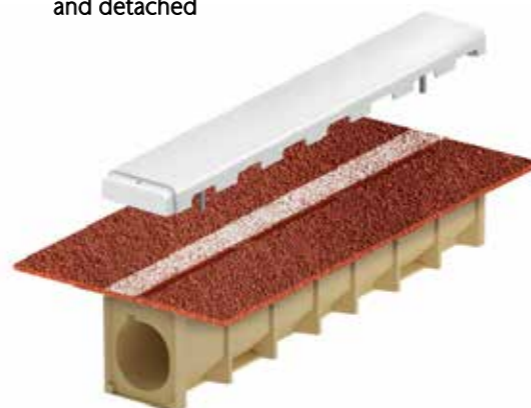

Inlet shaft for box channel



ACO has a wide spectrum of high-precision access covers and riser units for all load classes and for the complete range of shaft and sewage structures. The single and series covers use high quality technology to lengthen service lives and reduce operating costs.

ACO Access

Multiple and recessed covers for shafts and supply ducts



Typical Applications

- Telecommunication installations
- Airports and ports
- Railway stations
- Tunnels
- Bridges
- Emergency exits
- Water and gas supplies
- Control shafts
- Water treatment and sewage works

The ACO Secant range of shaft covers

The ACO Secant range of shaft covers is a very flexibly used system and it is available in various lengths. The covers can span shafts that have clear widths of up to 1,050 mm and they are offered for practically any preferred length of shaft. They are ideal for covering

inspection shafts, maintenance shafts, supply shafts and disposal shafts, as well as cable conduits or cable draw-shafts in industrial, public or private areas. The high-quality mechanical processing and the cover's sound seating ensure that this covering system is free of rattle and

wear, which prolongs the service life and reduces the ongoing operating costs. No cross-beams are required underneath the butt joints between the individual covers. The covered openings always remain entirely accessible. The clear width is unobstructed, e.g., for assembly work.



- Selectable surface
- Filled with concrete in the factory (BEGU cover)
- Supplied with a cast-iron frame
- Foldable and free of wear
- Optionally available with a screwed connection to prevent it from being lifted without permission
- The covers can be opened independently of each other, subject to bconsidering the opening direction
- One version has a device that prevents backflow from lifting it
- One version is sealed against surface water
- Covers are available in the B 125 und D 400 loading classes

The ACO Servokat GD shaft covers

The ACO Servokat GD shaft covers resist gas pressure and they are the right solution whenever the covers must be frequently handled for the purposes of maintenance or inspection. The covers have integrated opening devices that can be released by one person without any problem and without additional lifting aids. The covers are suitable for climbing out of the shaft in an emergency: they are equipped with special locks and reinforced opening devices according to the intended use: this means that the covers are particularly easy to open from underneath. The locks of these versions can be operated from above or below. The customer or his building contractor should take suitable measures during the design to protect the cover from freezing solid if it will be exposed to the weather, e.g., installing self-regulating heating strips.

- The screwed connection with an operating key can be opened and closed from above
- The cover is optionally available with a lock that can be rapidly released from underneath for climbing out of the shaft in an emergency
- A gasket seals the cover against surface water
- The surface has a diagonally ribbed, corrugated texture
- A gas-filled pneumatic spring enables the cover to be opened easily.
- The cover is automatically secured against slamming shut after it has been opened
- The opening angle of 88° ensures that one can climb into the shaft and out of it quickly and safely
- The material is galvanized steel or 1.4301 grade stainless steel



ACO References - India

ACO products provide you with reliable drainage wherever they are used. Versality and quality of ACO products will solve the most mundane problems of every day life, as well as the challenges of major projects.

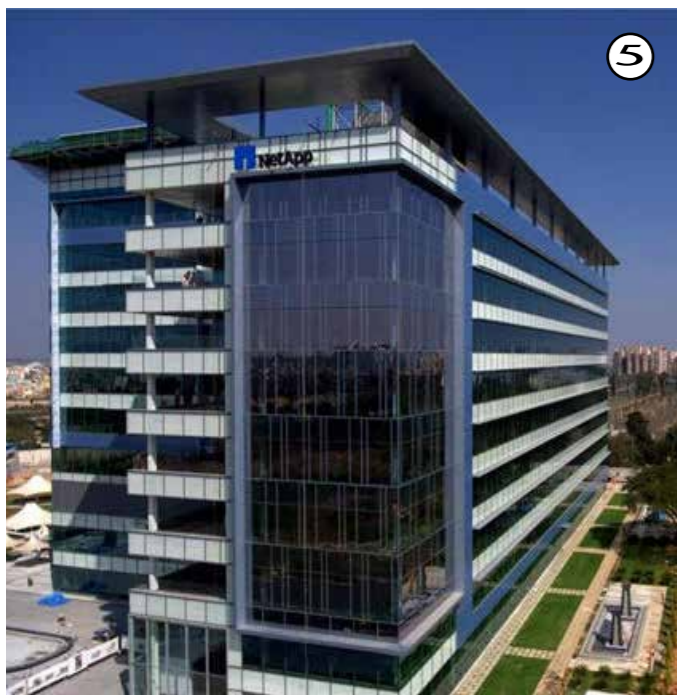

1. International Airport, New Delhi
2. Bihar Museum, Patna
3. Formula One track, New Delhi
4. Golden Temple, Amritsar
5. Netapp, Bangalore
6. Leela, Kovalam
7. Ritz Carlton, Bangalore
8. Tamara Resort, Kodaikanal
9. ITC Green Center, Bangalore
10. Shoba Developers, Bangalore
11. Taj Hotel, Mumbai



ACO References - International



1. Hotel Burj Al Arab, Dubai
2. Petronas Towers, Kuala Lumpur, Malaysia
3. Sapphire Tower, Istanbul
4. Westminster Cathedral, London
5. Formula 1 circuit, Shanghai
6. Central Fish Market, Kuwait
7. Airport, Frankfurt
8. Olympic Stadium, London
9. Potsdam Place, Berlin
10. Olympic Stadium, Beijing

The ACO Group Worldwide

www.aco.com

Australia
ACO Polycrete Pty Ltd
Emu Plains, Sydney
Adeleide
Brisbane
Melbourne
Perth
www.acoaus.com.au

Austria
ACO GmbH
Baden
www.aco.co.at

Belgium
ACO Passavant NV/SA
Merchtem
www.aco.be

Bosnia and Herzegovina
ACO d.o.o.
Sarajevo
www.aco.ba

Bulgaria
ACO Building Elements Ltd
Sofia
www.aco.bg

Brazil
ACO Soluções em Drenagem LTDA
Rio Abaixo, Jacaref - São Paulo
www.acodrenagem.com.br

Canada
ACO Systems Ltd.
Mississauga, Ontario
www.acocan.ca

Chile
ACO SpA
Santiago de Chile
www.aco-spa.cl

China
ACO Drainage Technology
Co. Ltd.
Shanghai
www.aco.cn

ACO Technologies Ltd.
Hongkong
www.aco.cn

Colombia
ACO Soluciones de Drenaje
Bogota
www.aco.com.co

Croatia
ACO Grdevinski elementi d.o.o.
Zagreb
www.aco.hr
Czech Republic
ACO Industries k.s.
Přibyslav
www.aco.cz

ACO Stavební prvky spol. s.r.o.
Jihlava
www.aco.cz

ACO Industries Tabor s.r.o.
Sezimovo Ústí
www.aco.cz

ACO Marine s.r.o.
Prague
www.acomarine.com

Denmark
ACO Nordic A/S
Ringsted
www.aco.dk

Plastmo A/S
Ringsted
www.plastmo.dk

ACO Funki A/S
Herning
www.aco-funki.com

Hvidbjerg Vinduet A/S
Hvidbjerg/Thyholm
www.hvidbjergvinduet.dk

Estonia
ACO Nordic OÜ
Tallinn
www.aco.ee

Finland
ACO Nordic Oy
Espoo, Helsinki
www.acodrain.fi

France
ACO s.a.s
Notre Dame de l'Isle
www.aco.fr

ACO Funki France
Landerneau
www.aco-funki.com

ACO Hydrocast SAS
Saint Romain de Jalionas

www.hydrocast.fr

Germany (Headquarter)
ACO Severin Ahlmann
GmbH & Co. KG
Rendsburg/Büdelndorf
www.aco.com

ACO Tiefbau Vertrieb GmbH
Rendsburg/Büdelndorf
www.aco-tiefbau.de

ACO Hochbau Vertrieb GmbH
Reith
www.aco-hochbau.de

ACO Selbstbau Vertrieb GmbH
Rendsburg/Büdelndorf
www.aco-selbstbau.de

ACO Passavant GmbH
Philippsthal
Stadtlengsfeld
www.aco-haustechnik.de

ACO Beton GmbH
Bürstadt
www.aco.com

ACO Guss GmbH
Kaiserslautern
www.aco-guss.com

ACO Passavant Guss GmbH
Michelbacher Hütte, Aarbergen
www.aco.com

ACO Eurobar GmbH
Kaiserslautern
www.aco-eurobar.de

ACO Edelstahl GmbH
Philippsthal
www.aco-industrie.de

ACO Industrie Vertrieb GmbH
Philippsthal
www.aco-industrie.de

ACO Funki A/S
Rendsburg/Büdelndorf
www.aco-funki.de

Aguss Vertrieb GmbH
Michelbacher Hütte, Aarbergen
www.aguss.de

HAVO Strangguss GmbH
Plettenberg
www.havo-strangguss.de

Inotec Sportanlagen-
und Edelstahltechnik GmbH
Rendsburg/Büdeltsdorf
www.inotec.biz

Hungary
ACO Kereskedelmi Kft.
Dunaharaszti, Budapest
www.aco.hu

India
ACO Systems and Solutions Pvt.
Ltd.
Bangalore
www.aco.in

ACO Technology Centre Pvt. Ltd.
Bangalore
www.aco.in

Italy
ACO Passavant S.p.A
Bagnolo in Piano
www.aco.it

Latvia
ACO Nordic SIA
Riga
www.aco.lv

Lithuania
ACO Nordic UAB
Vilnius
www.aco.lt

Malaysia
ACO Polycrete Pty Ltd
Kuala Lumpur
www.acoaus.com.au

Mexico
ACO Productos de Contruccion,
S.A. de C.V.
Tlalnepantla, Mexico City
www.acomex.com.mx

Morocco
ACO Solutions de Drainage
Aïn Atiq
www.aco.fr

Netherlands
ACO B. V.
Doetinchem
www.aco.nl

New Zealand
ACO Limited
Auckland

www.aconz.co.nz
Norway
ACO Nordic A/S
Lysaker
www.acodrain.no
Plastmo A/S
Slemmestad
www.plastmo.no

Poland
ACO Elementy Budowlane
Sp.z o.o.
Legionowo, Warsaw
www.aco.pl

Plastmo Polska Sp. z o.o.
Janki, Warsaw
www.plastmopolska.pl

ACO Funki Sp. z o. o.
Gorzno
www.aco-funki.com

Portugal
Lusitana ACO
Elementos de Construção,
Unipessoal Lda.
Matosinhos
www.aco.pt

Romania
ACO s.r.l.
Afumati
www.aco.ro

Russia
ACO Drainage Solutions LLC
Moscow
www.acodrain.ru

Serbia
ACO gradjevinski elementi d.o.o.
Belgrade
www.aco.rs

Slovakia
ACO Stavebné prvky, s.r.o.
Bratislava
www.aco.sk

Slovenia
ACO gradbeni elementi,
zastopanje, d.o.o.
S`marje pri Jels`ah
www.aco.si

South Africa
ACO Systems SA
Germiston, Johannesburg
www.aco.co.za

ACO Casting Services South Africa (Pty) Ltd
Johannesburg
www.aco-cast-iron.co.za

Spain
ACO Productos Polímeros, S.A.
Maçanet de la Selva
www.aco.es

Sweden
ACO Nordic AB
Sävedalen, Göteborg
www.aco-nordic.se

Switzerland
ACO Passavant AG
Netstal, GL
www.aco.ch

Turkey
ACO Yapi Malzemeleri San. ve Tic. Ltd. Sti.
Istanbul
www.aco.com.tr

Ukraine
ACO Building Elements Ltd.
Kiev
www.aco.ua

United Arab Emirates
ACO Systems FZE
Dubai
www.aco.ae

United Kingdom
ACO Technologies plc
Shefford
www.aco.co.uk

ACO Building Drainage
Bedford
www.acobuildingdrainage.co.uk

USA
ACO Polymer Products, Inc.
Casa Grande, AZ
Mentor,
OH
Fort Mill, SC
www.acousa.com